

DAIHATSU
F70, F75, F77

Service
manual

PROPELLER SHAFT

PR

DAIHATSU MOTOR CO., LTD.

NO.9703-FE

DAIHATSU

F70, F75, F77

PROPELLER SHAFTS

FRONT

SECTIONAL VIEW PR- 2

TROUBLE SHOOTING PR- 2

COMPONENTS (FRONT & REAR) PR- 3

REPLACEMENT OF PROPELLER SHAFT
WITH NEW ONE

REMOVAL PR- 4

INSTALLATION PR- 4

CASE WHERE PROPELLER SHAFT IS
REUSED

REMOVAL PR- 6

INSPECTION PR- 7

INSTALLATION PR- 8

REPLACEMENT OF UNIVERSAL JOINT
SPIDER S/A (FRONT & REAR)

REMOVAL PR- 9

INSPECTION PR-13

INSTALLATION PR-13

REAR

SECTIONAL VIEW PR-17

TROUBLE SHOOTING PR-17

REPLACEMENT OF PROPELLER SHAFT
WITH NEW ONE

REMOVAL PR-18

INSTALLATION PR-18

CASE WHERE PROPELLER SHAFT IS
REUSED

REMOVAL PR-20

INSPECTION PR-21

INSTALLATION PR-21

SSTs PR-23

SERVICE SPECIFICATIONS PR-23

TIGHTENING TORQUE PR-23

WRE91-PR001

PROPELLER SHAFTS

FRONT PROPELLER SHAFT

The front propeller shaft employs a two-joint type.
Furthermore, the universal joint spiders adopt an outer snap ring as its securing method.

WRE91-PR002

SECTIONAL VIEW

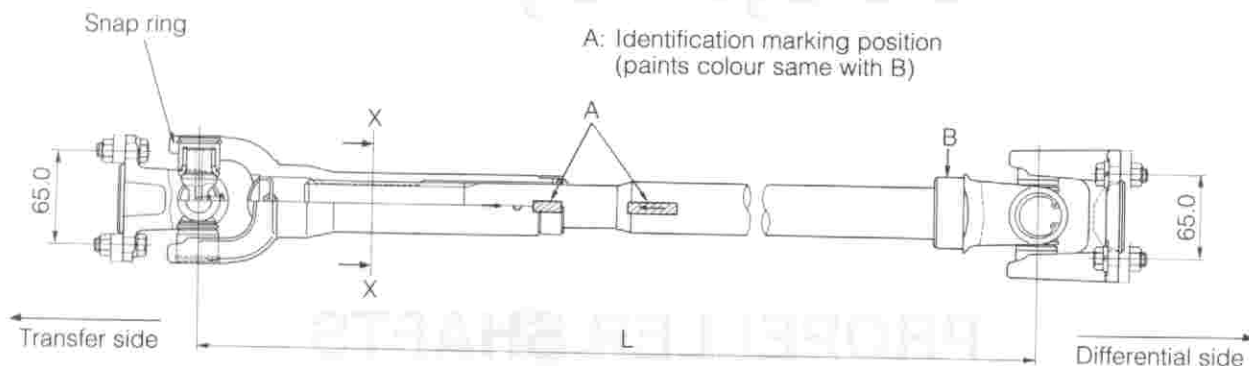

B: Identification marking position

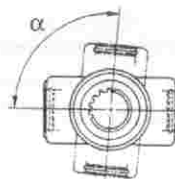
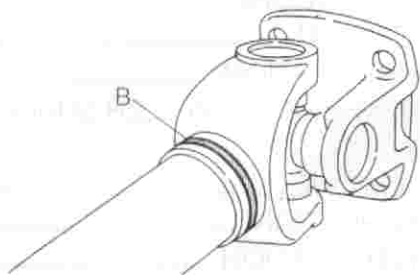

X - X section

Unit: mm

MODEL	Type of transmission	Joint to joint interval (L)	Phase angle (α)	B
F70, F75, F77	4-speed	463	104°	White
	5-speed	567	115.5°	White

WRE91-PR003

TROUBLE SHOOTING

Symptom	Possible causes	Checking points
Abnormal noise Vibration	<ul style="list-style-type: none"> • Universal joint improperly lubricated • Universal joint spider section damaged • Runout or damage of propeller shaft 	<ul style="list-style-type: none"> • Lubrication to grease nipple • Check universal joint. • Check propeller shaft for runout.

WRE91-PR004

PROPELLER SHAFT (FRONT & REAR)

COMPONENTS

T : Tightening torque
 Unit : N·m (kgf·m)
 ★ : Non reusable parts
 ◀ : Selection parts
 □ : Parts supply as a set

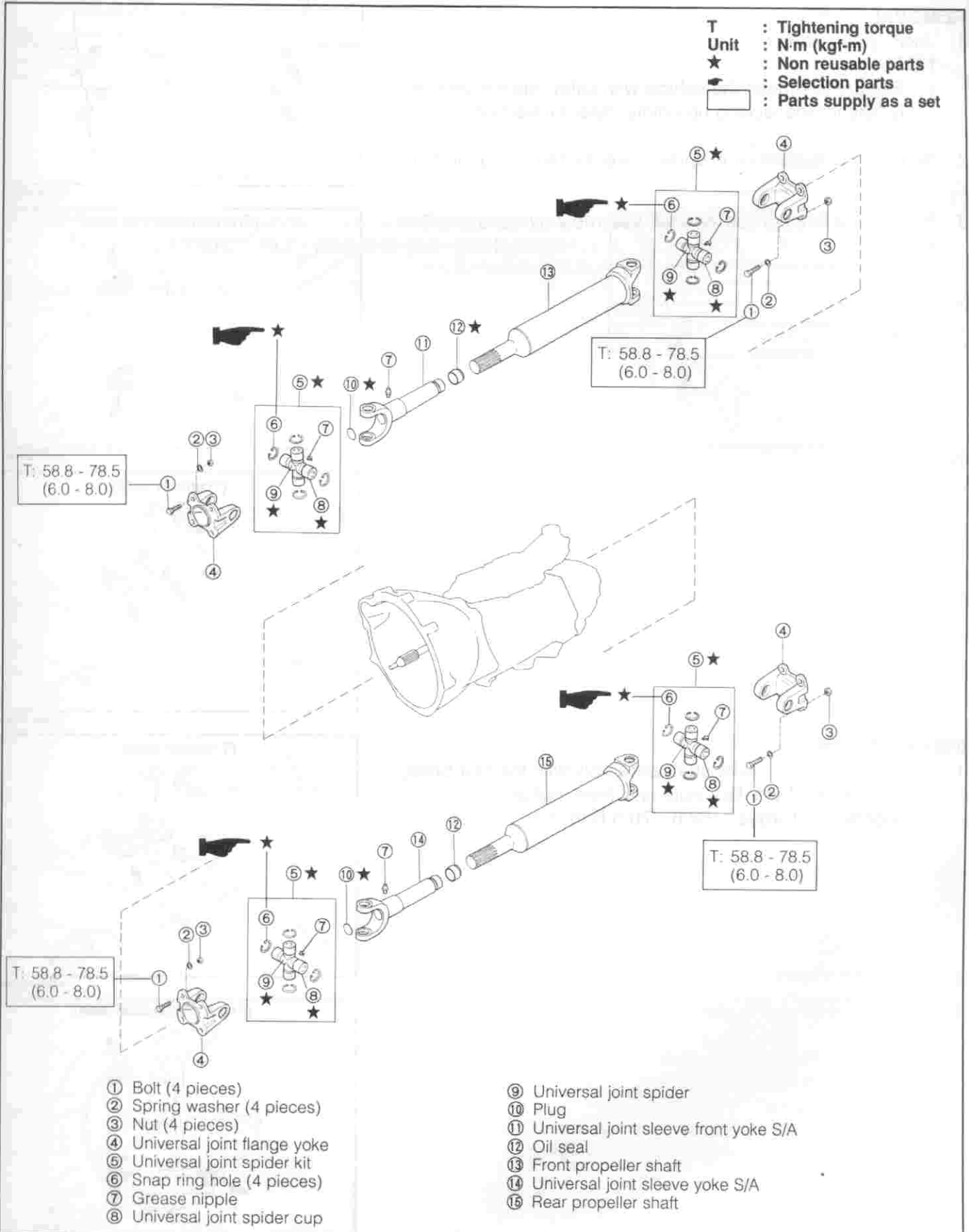

- ① Bolt (4 pieces)
- ② Spring washer (4 pieces)
- ③ Nut (4 pieces)
- ④ Universal joint flange yoke
- ⑤ Universal joint spider kit
- ⑥ Snap ring hole (4 pieces)
- ⑦ Grease nipple
- ⑧ Universal joint spider cup

- ⑨ Universal joint spider
- ⑩ Plug
- ⑪ Universal joint sleeve front yoke S/A
- ⑫ Oil seal
- ⑬ Front propeller shaft
- ⑭ Universal joint sleeve yoke S/A
- ⑮ Rear propeller shaft

PROPELLER SHAFTS

REPLACEMENT OF PROPELLER SHAFT WITH NEW ONE (FRONT)

REMOVAL

1. Jack up the vehicle.

NOTE:

- Be sure to support the vehicle with safety stands securely. (As for the jacking up points, refer GI-section).

2. Remove the transmission under cover by removing the four bolts.
3. Remove the front propeller shaft assembly by removing the four bolts.

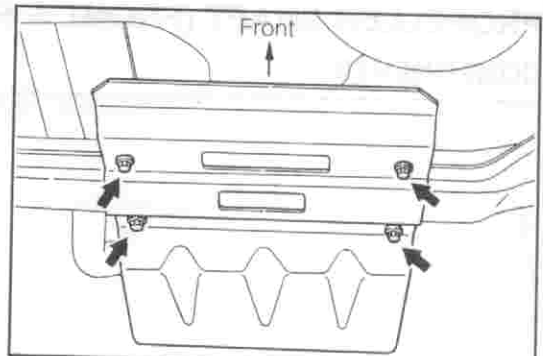

WRE91-PR006

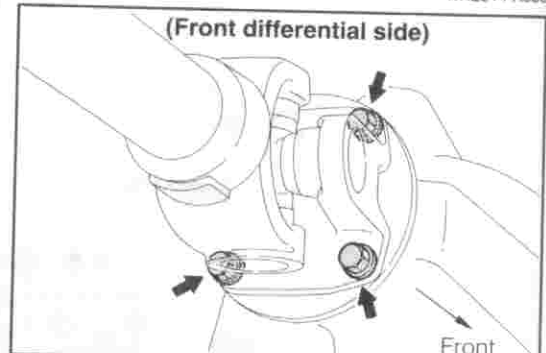

WRE91-PR007

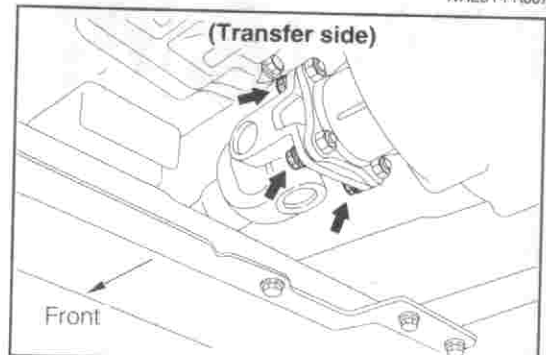

WRE91-PR008

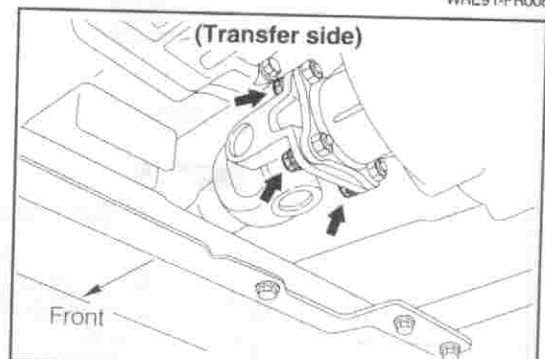

WRE91-PR009

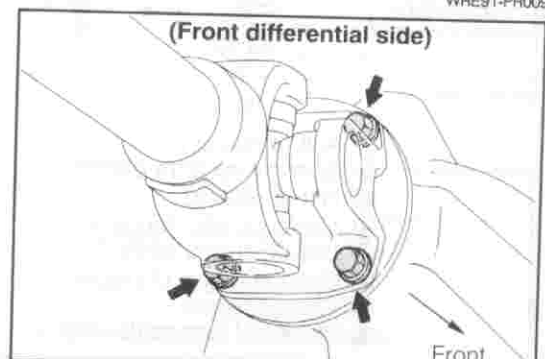

WRE91-PR010

INSTALLATION

1. Install the front propeller shaft assembly with the four bolts, four spring washers, four nuts and then, tighten the nuts.
Tightening Torque: 58.8 - 78.5 N-m (6.0 - 8.0 kgf-m)

2. After installing the propeller shaft, apply black paint to the exposed machined surface of the differential (slant line section in the right figure) as a rust preventive measure.

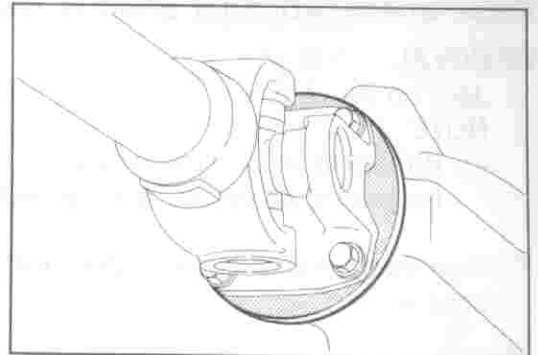

WRE91-PR011

3. Tighten the transmission under cover with the four bolts.
Tightening Torque: 15.7 - 23.5 N·m (1.6 - 2.4 kgf·m)

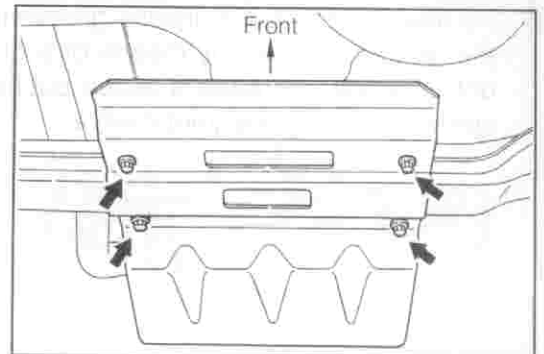

WRE91-PR012

4. Jack down the vehicle.

PROPELLER SHAFTS

Case where propeller shaft is reused

REMOVAL

1. Jack up the vehicle.

NOTE:

- Be sure to support the vehicle with safety stands. (As for the jacking up points, refer GI-section).

2. Remove the transmission undercover by removing the four bolts.

3. Fill new lithium multi-purpose grease into each grease nipple (at three points) by means of a grease gun or the like, until all existing grease is oozed out from the universal joint spider and universal joint sleeve.

4. Check the universal joint sleeve spline for excessive looseness by turning the propeller shaft in one direction and the universal joint sleeve in the opposite direction.

NOTE:

- If any abnormal looseness is present, replace the propeller shaft assembly or universal joint spider set with new one.

5. Move the center of the propeller shaft in up-&-down and right-&-left directions so as to check the universal joint spider for excessive play by hand feeling.

NOTE:

- If the universal joint spider exhibits abnormal looseness, measure the starting torque. (See page PR-14.)

6. Remove the front propeller shaft by removing the four bolts.

CAUTION:

- Prior to the removal, mating marks should be put on each of the flange yoke and companion flange of the front differential.
- If this operation should fail to be performed, the propeller shaft may emit abnormal noise or vibration during the running.

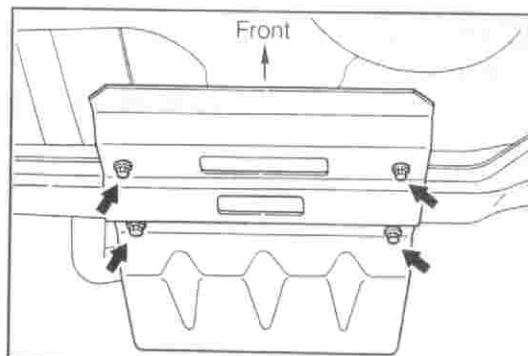

WRE91-PR013

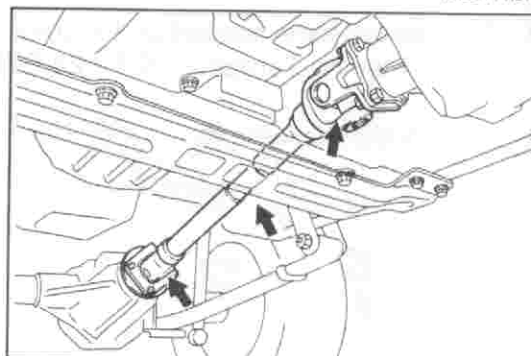

WRE91-PR014

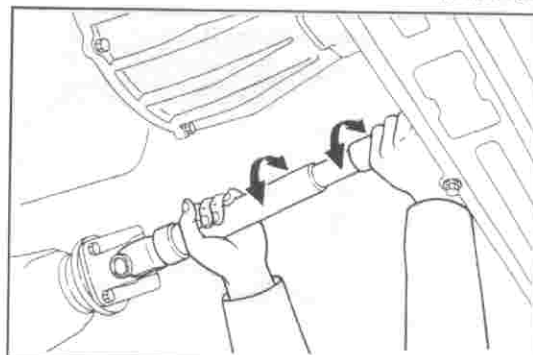

WRE91-PR015

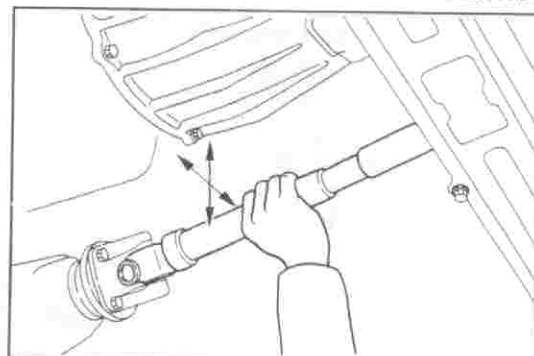

WRE91-PR016

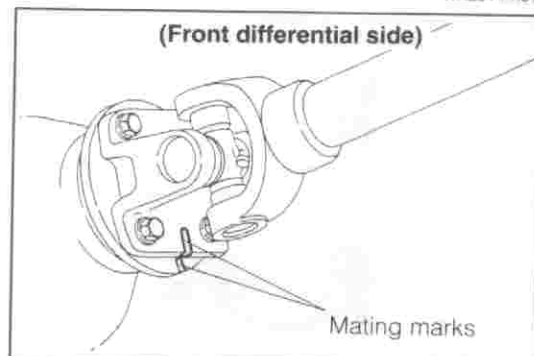

WRE91-PR017

INSPECTION

1. With a dial gauge placed at the center of the propeller shaft, measure the runout.

Allowable Runout Limit: 0.5 mm

Replace to the new front propeller shaft, if the runout is exceed than 0.5 mm

2. Check to see if any damage is present at the seal of the spider section of the universal joint.

3. Check the flange yoke and sleeve yoke.
 - (1) Inspect to see if any damage is present at the differential drive pinion companion flange-contact section ①.
 - (2) Check the oil seal sliding section ② for damage or wear.
 - (3) Check the spline ③ for damage or wear.
 - (4) Fit the sleeve yoke onto the sliding spline of the transmission output shaft.

Ensure that the spline exhibits no looseness in the rotation direction and the sleeve can slide freely in the axial direction on the spline.

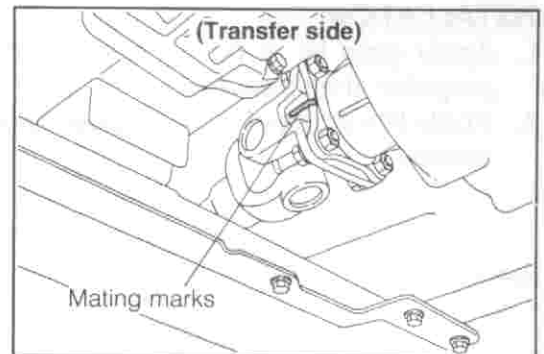

WRE91-PR018

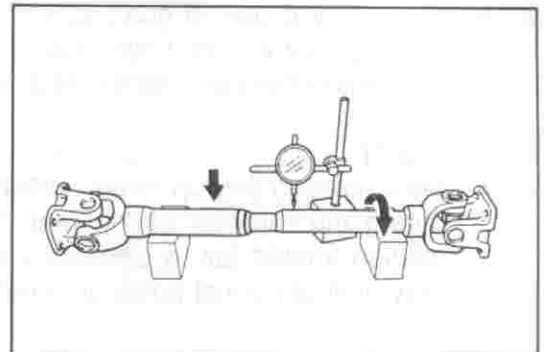

WRE91-PR019

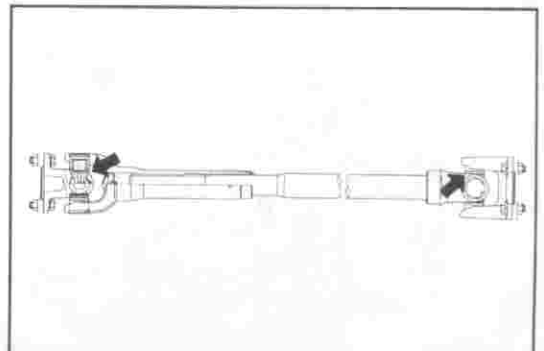

WRE91-PR020

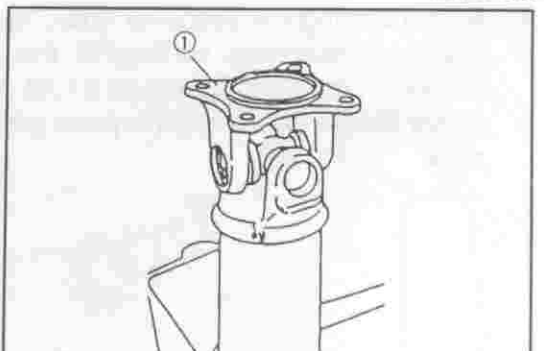

WRE91-PR021

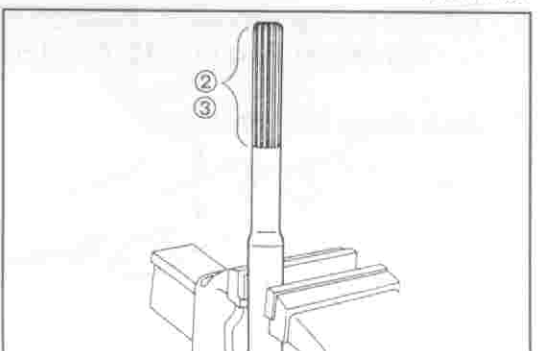

WRE91-PR022

PROPELLER SHAFTS

INSTALLATION

1. Apply gear oil to both the inner and outer sides of the propeller shaft sleeve.
2. Apply lithium base multi purpose grease to the oil seal lip section.

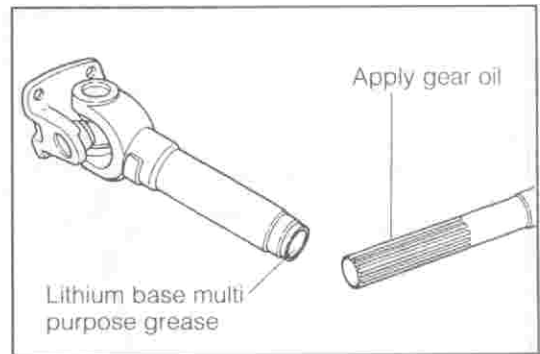

3. Install the rear propeller shaft assembly with the four bolts, four spring washers, four nuts then, tighten the nuts.
Tightening Torque: 58.8 - 78.5 N-m (6.0 - 8.0 kgf-m)

CAUTION:

- Make sure to line up those scribing lines that were put during the removal of the rear propeller shaft. If this caution should fail to be observed, the propeller shaft may emit abnormal noise or vibration.

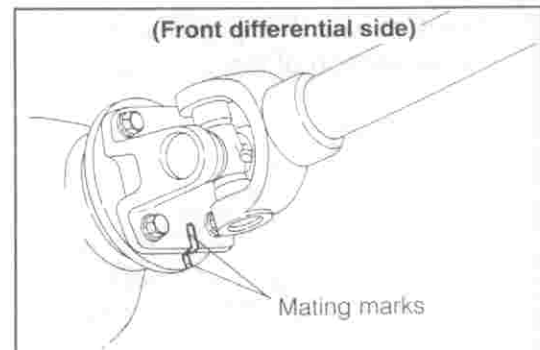
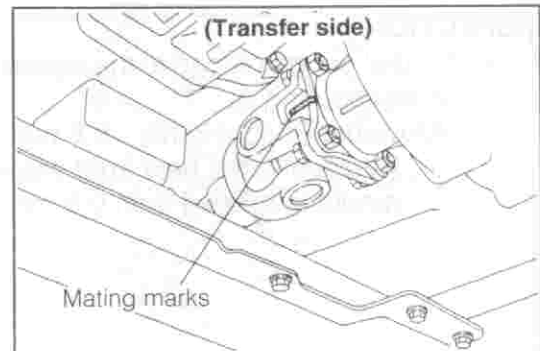

4. After installing the propeller shaft, apply black paint to the exposed machined surface of the differential (slant line section in the right figure) as a rust preventive measure.
5. Apply lithium base multi-purpose grease to the grease nipples.

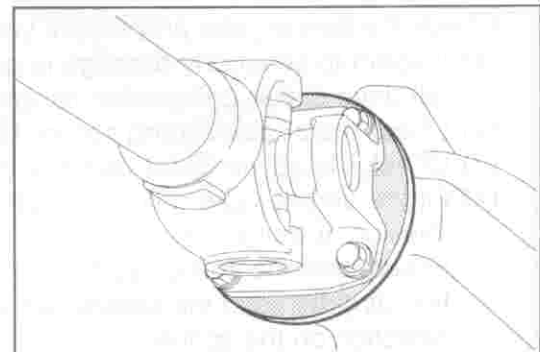

6. Tighten the transmission under cover with the four bolts.
Tightening Torque: 15.7 - 23.5 N-m (1.6 - 2.4 kgf-m)

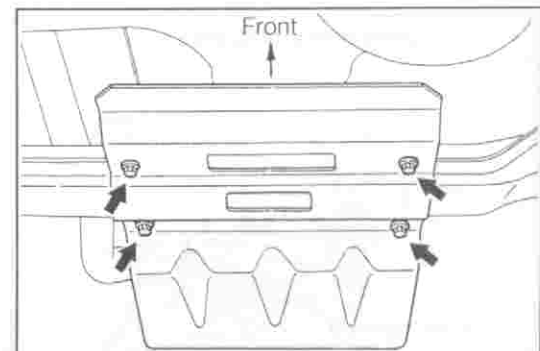

7. Jack down the vehicle.

REPLACEMENT OF UNIVERSAL JOINT SPIDER SUBASSEMBLY (FRONT & REAR)

NOTE:

- The removal procedure for the universal joint spider subassembly is the same both front side and rear side. Therefore, the procedure for the front side (at the differential side) only is described here.

WRE91-PR028

REMOVAL

1. Jack up the vehicle.

NOTE:

- Be sure to support the vehicle with safety stands securely. (As for the jacking up points, refer GI-section).

2. Remove the transmission under cover by removing the four bolts.

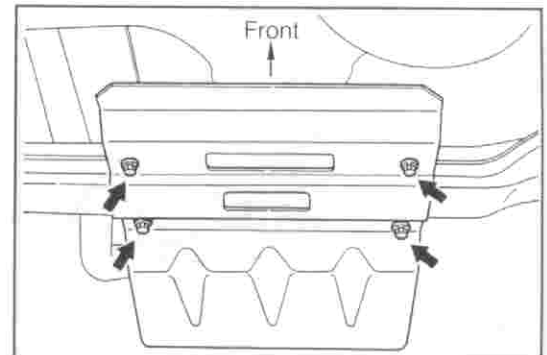

WRE91-PR029

3. Fill new lithium multi-purpose grease into each grease nipple (at three points) by means of a grease gun or the like, until all existing grease is oozed out from the universal joint spider and universal joint sleeve.

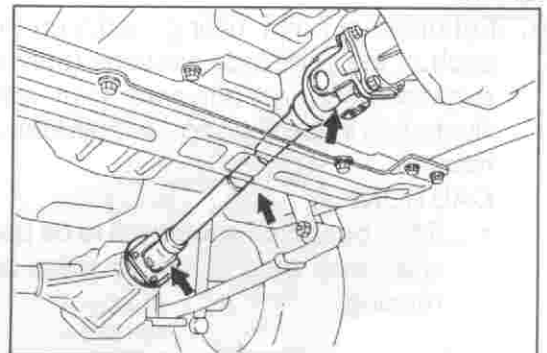

WRE91-PR030

4. Check the universal joint sleeve spline for excessive looseness by turning the propeller shaft in one direction and the universal joint sleeve in the opposite direction.

NOTE:

- If any abnormal looseness is present, replace the propeller shaft assembly or universal joint spider set with new one.

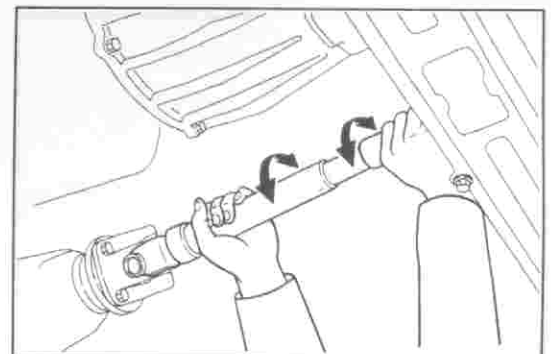

WRE91-PR031

5. Move the center of the propeller shaft in up-&-down and right-&-left directions so as to check the universal joint spider for excessive play by hand feeling.

NOTE:

- If the universal joint spider exhibits abnormal looseness, measure the starting torque. (See page PR-14.)

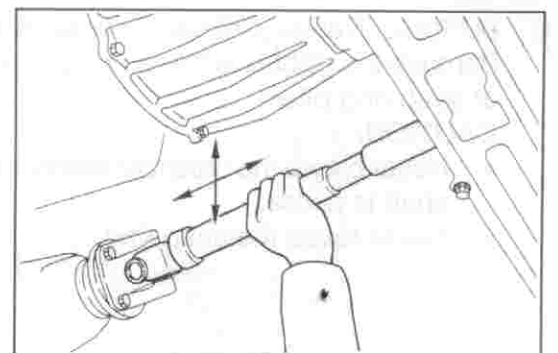

WRE91-PR032

PROPELLER SHAFTS

6. Remove the front propeller shaft by removing the four bolts.

CAUTION:

- Prior to the removal, mating marks should be put on each of the flange yoke and companion flange of the front differential.
- If this operation should fail to be performed, the propeller shaft may emit abnormal noise or vibration during the running.

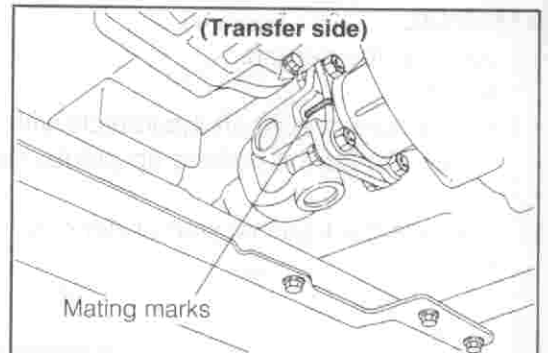
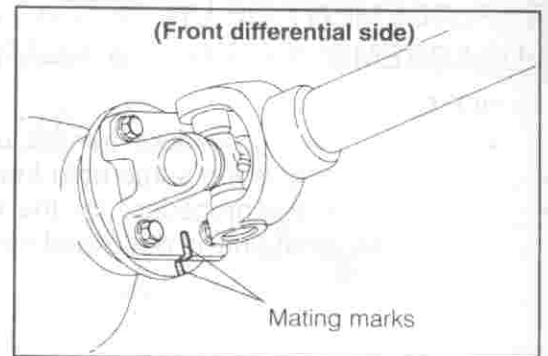

7. Put different paint mating marks on the propeller shaft and each of the yoke side sections (universal joint sleeve yoke subassembly and universal joint with flange yoke). (The illustration in the right figure indicates an example of mating marks.)

CAUTION:

- If this operation should fail to be performed, the propeller shaft may emit abnormal noise or vibration during the running.

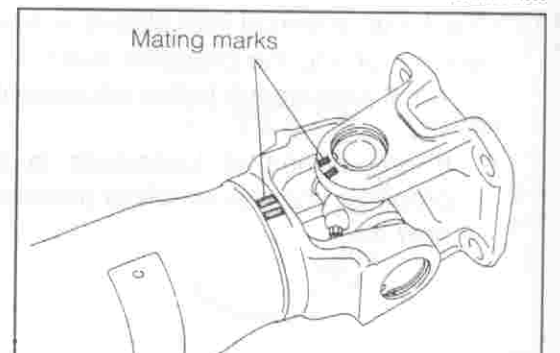
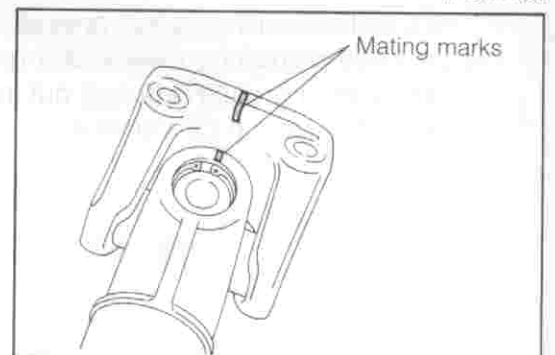

8. Set the universal joint sleeve yoke in a vice. Remove the right & left snap rings, using the standard tool of snap ring pliers.

CAUTION:

- Never clamp the balancer weight section of the propeller shaft in a vise.
- Never reuse the snap ring.

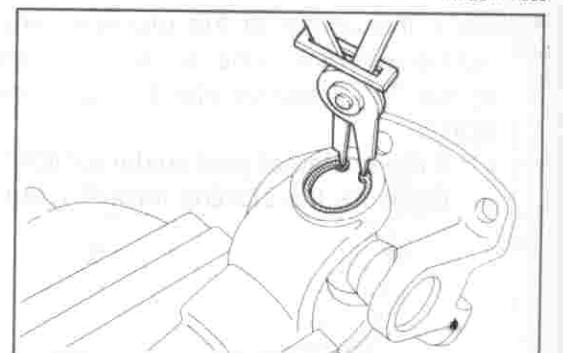

9. Push down the right and left universal joint spider bearing cups, using the suitable wrench box and the following SSTs.
 SST: 09520-87604-000
 09956-00010-000

NOTE:

- At this stage, the universal joint spider bearing cups can not be removed completely.
- Prior to the removal, be sure to remove the black paint at the periphery of the universal joint spider bearing cup.

10. Lift the universal joint flange yoke S/A. Install a furnished ring to the shaft section of the universal joint spider.

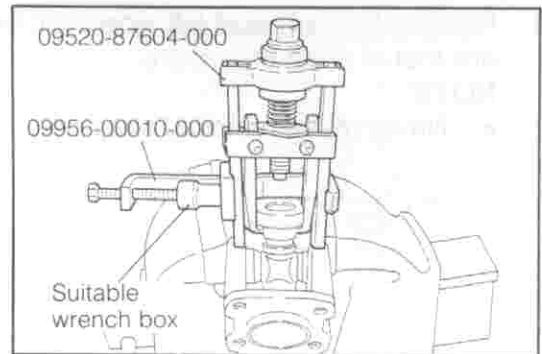

WRE91-PR038

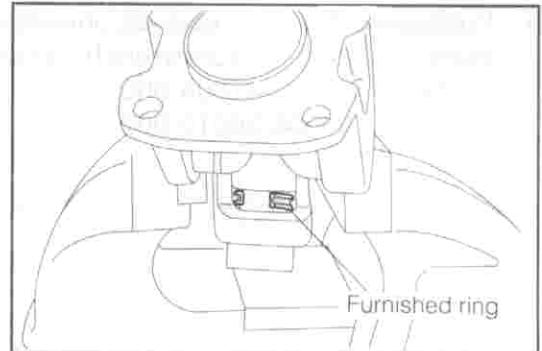

WRE91-PR039

11. Remove the universal joint spider bearing cup at one side, using a suitable wrench box and the following SSTs.
 SST: 09520-87604-000
 09956-00010-000

CAUTION:

- Never reuse the removed universal joint spider bearing cup.

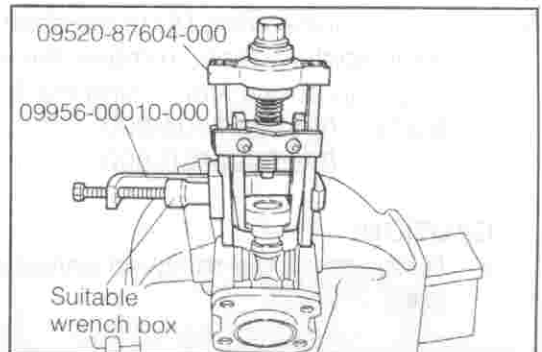

WRE91-PR040

12. Remove the universal joint flange yoke from the universal joint sleeve yoke.

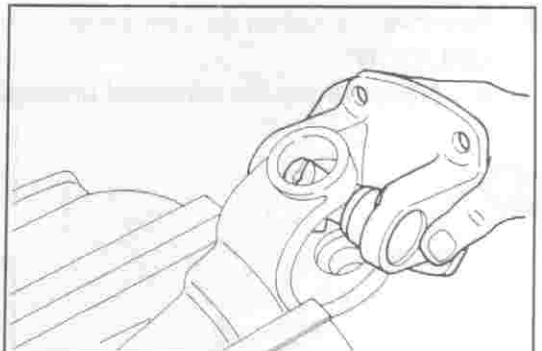

WRE91-PR041

13. Remove the universal joint spider bearing cup by lightly tapping it, using a hammer in combination with a suitable metal rod.

CAUTION:

- Never reuse the removed universal joint spider bearing cup.

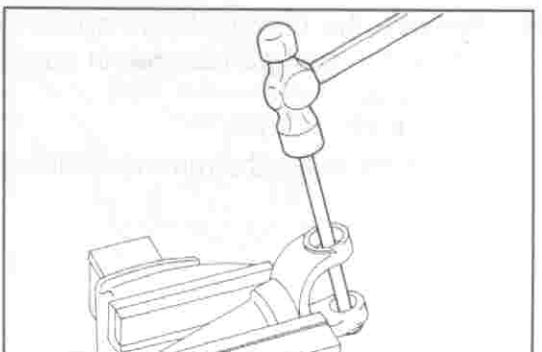

WRE91-PR042

PROPELLER SHAFTS

14. Remove the right and left side snap rings, using the standard tool of snap ring pliers.

NOTE:

- Never reuse removed snap ring.

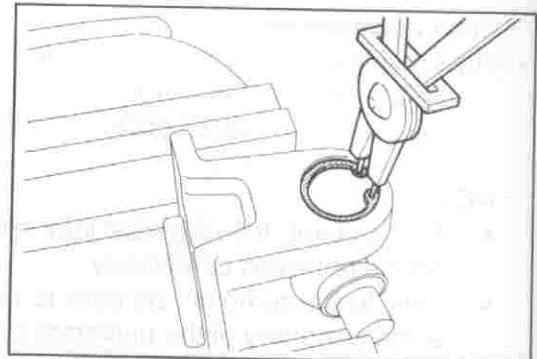

WRE91-PR043

15. Push down the right and left universal joint spider bearing cups, using the suitable wrench box and the following SSTs.

SST: 09520-87604-000

09956-00010-000

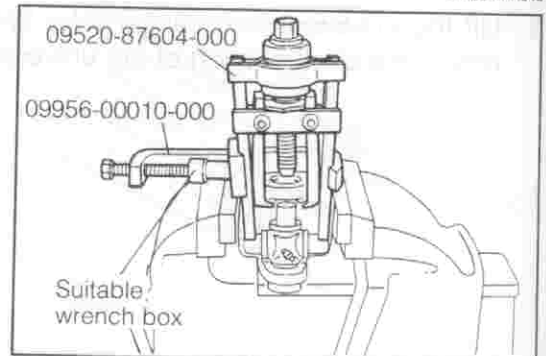

WRE91-PR044

16. Install a furnished ring (A) to the shaft section of the universal joint spider. Then, remove the universal joint spider bearing cup at one side, using the following SSTs.

SSTs: 09520-87604-000

09956-00010-000

CAUTION:

- Never reuse the removed universal joint spider bearing cup.

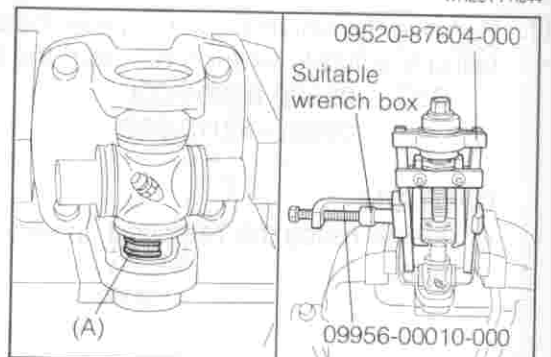

WRE91-PR045

17. Remove the universal joint spider.

CAUTION:

- Never reuse the removed universal joint spider.

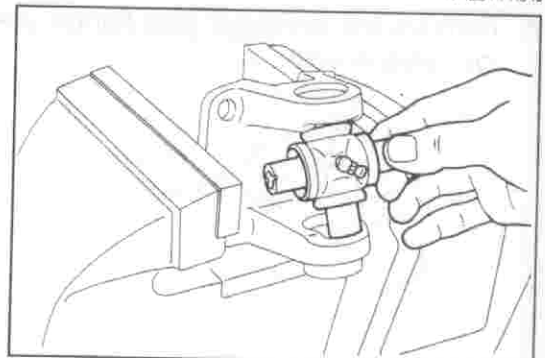

WRE91-PR046

18. Remove the universal joint spider bearing cup by lightly tapping it, using a hammer in combination with a suitable metal rod.

CAUTION:

- Never reuse the removed universal joint spider bearing cup.

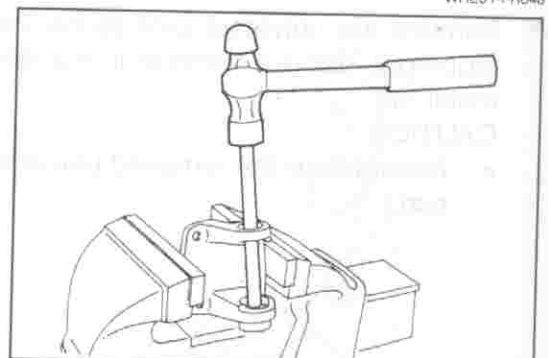

WRE91-PR047

INSPECTION

1. Conduct measurement at the two sections of A and B (cross direction) indicated in the right figure, using an inner dial gauge.

Specified Value:

- Sleeve Yoke
28.0 ^{+0 mm}/_{+0.021 mm}
- Flange Yoke
28.0 ^{+0 mm}/_{+0.021 mm}

CAUTION:

- If the inner diameters of the sections A and B exceed the specified value above, replace the parts with new one.

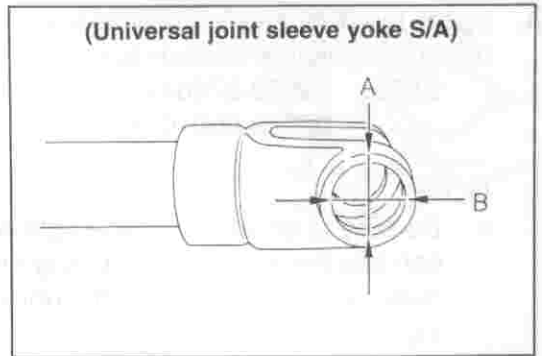

WRE91-PR048

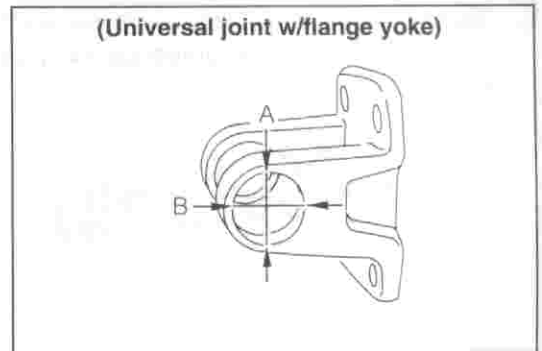

WRE91-PR049

INSTALLATION

1. The following parts (1), (2), (3) are supplied in one set in the replacement parts for the universal joint spider subassembly.

- (1) Universal joint spider 1 piece
- (2) Universal joint spider bearing cup 4 pcs.
- (3) Snap ring 4 pcs.

Parts availability	Identification
T = 1.45 mm	None
T = 1.50 mm	Yellow paint applied on ring outer periphery
T = 1.55 mm	White paint applied on ring outer periphery

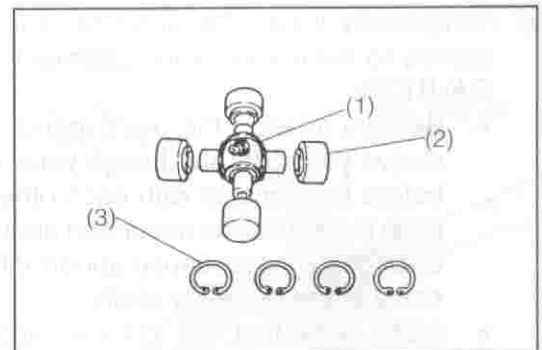

WRE91-PR050

2. Temporarily install new universal joint spider bearing cups (two pcs.) to the universal joint with flange yoke, by pushing them with fingers.

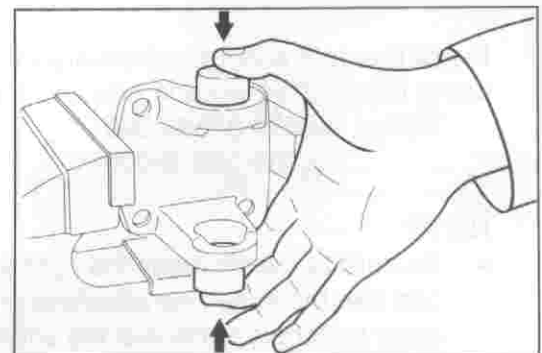

WRE91-PR051

3. Set a new universal joint spider to the universal joint sleeve yoke S/A.

NOTE:

- Make sure that the grease nipple faces toward the universal joint w/flange yoke.

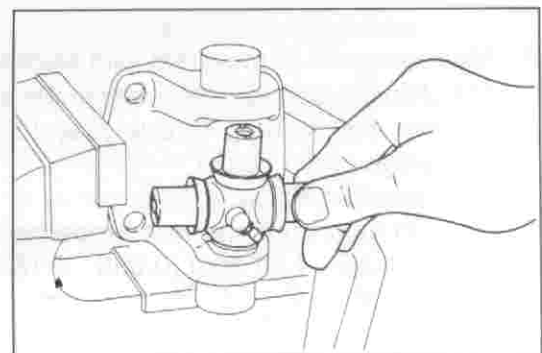

WRE91-PR052

PROPELLER SHAFTS

4. Install the right and left universal joint spider bearing cups, using the suitable wrench box and the following SSTs.

SSTs: 09520-87604-000
09956-00010-000

NOTE:

- Be sure to evenly press the right and left cups, until you can see the snap ring attaching groove provided on the outer periphery surface of the universal joint spider bearing cup.

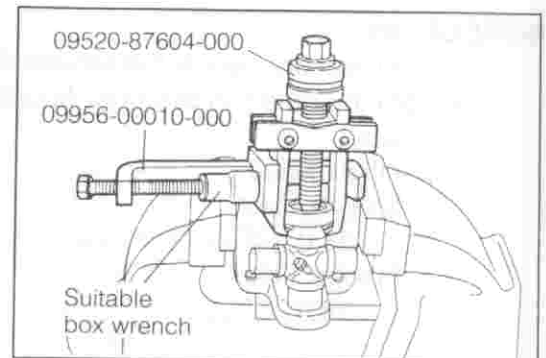

5. Temporarily install new universal joint spider bearing cups (right and left) to the universal joint sleeve yoke by pushing them with finger.

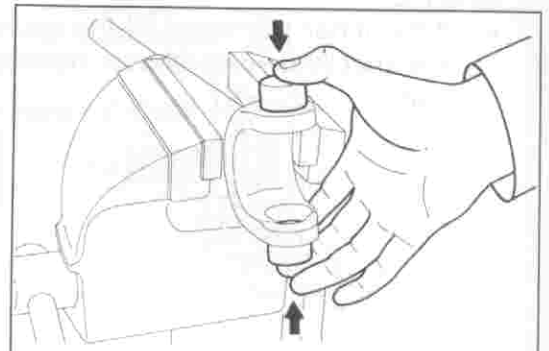

6. Temporarily install the universal joint flange yoke subassembly to the universal joint sleeve yoke S/A.

CAUTION:

- Be sure to align the paint marks (at the universal joint sleeve yoke S/A and flange yoke sides) which were put before the removal with each other.
If the mating marks described above are not aligned with each other, it may cause abnormal vibration or abnormal noise of the propeller shaft.
- Make sure that the grease nipple faces toward the propeller shaft side.

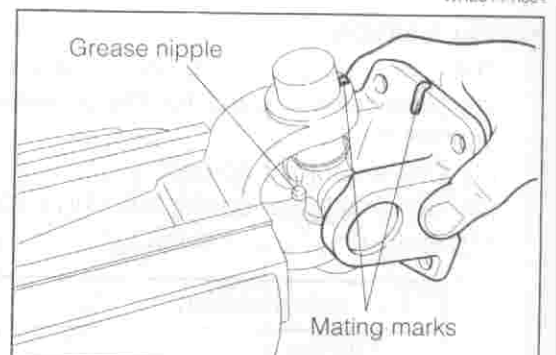

7. Install the right and left universal joint spider bearing cups, using the suitable wrench box and the following SSTs.

SSTs: 09520-87604-000
09956-00010-000

NOTE:

- Be sure to evenly press the right and left cups, until you can see the snap ring attaching groove provided on the outer periphery surface of the universal joint spider bearing cup.

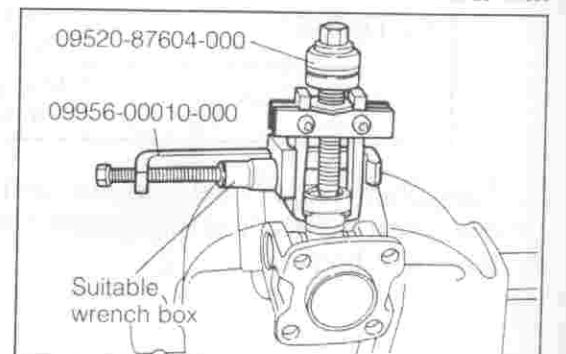

8. Measurement of universal joint starting torque

- (1) Using a spring scale, install the selected snap ring so that the starting torque may fall within the specified range given below.

Specified Value

(On both front and rear propeller shafts):

0.05 - 1.47 N·m (0.005 - 0.15 kgf·m)

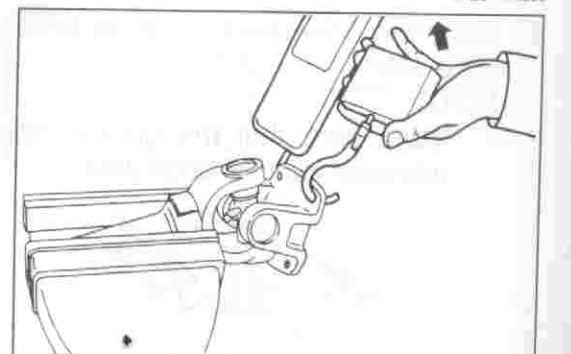

(2) Turn the propeller shaft 90 degrees. Measure the starting torque.

CAUTION:

- As regards the snap rings positioned symmetrically relative to the universal joint spider, in principle, it is required to use the snap rings having the same thickness.
- However, if the starting torque does not reach or exceeds the specified range despite the fact that the snap rings having the same thickness have been used, use a snap ring having one class higher or lower thickness.

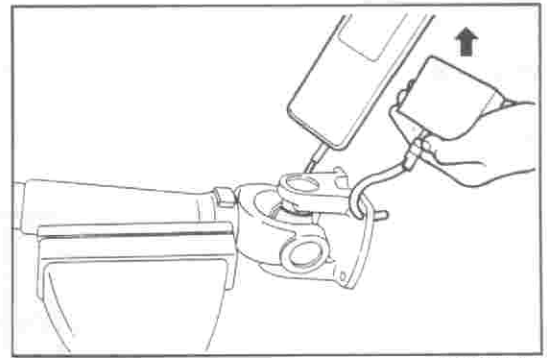

9. With a dial gauge placed at the center of the propeller shaft, measure the runout.

Allowable Runout Limit: 0.5 mm
 Replace to the new front propeller shaft, if the runout is exceed than 0.5 mm

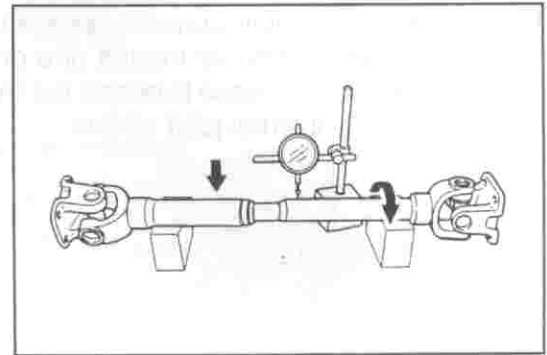

10. Apply gear oil to both the inner and outer sides of the propeller shaft.
11. Apply the lithium base multi purpose grease to the oil seal lip section.

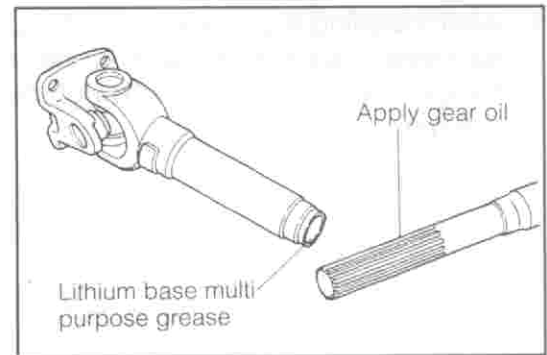

12. Insert the universal joint yoke and universal joint sleeve yoke S/A.

CAUTION:

- Make sure to line up those mating marks that were put during the factory of the propeller shaft. If this caution should fail to be observed, the propeller shaft may emit abnormal noise or vibration.

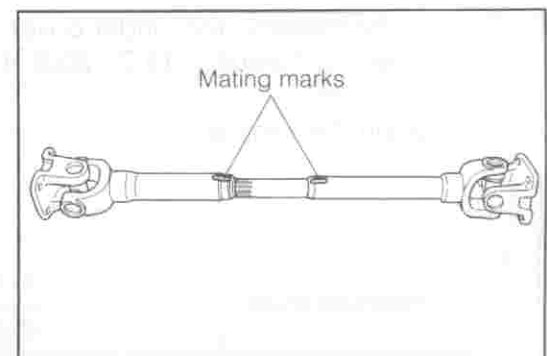

13. Install the propeller shaft with the mating marks that were put during the removal of the propeller shaft aligned with each other.

Tightening Torque: 58.8 - 78.5 N·m (6.0 - 8.0 kgf·m)

CAUTION:

- Make sure to line up those mating marks that were put during the removal of the front propeller shaft. If this caution should fail to be observed, the propeller shaft may emit abnormal noise or vibration.

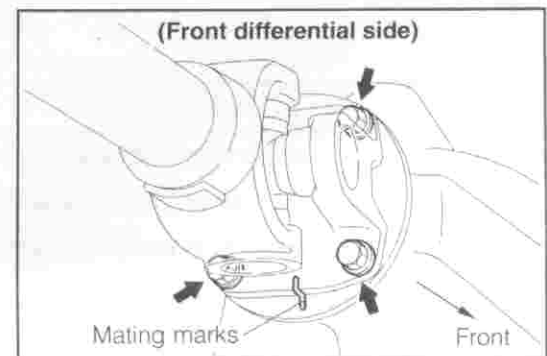

PROPELLER SHAFTS

14. Fill new lithium multi-purpose grease into each grease nipple (at three points) by means of a grease gun or the like, until all existing grease is oozed out from the universal joint spider and universal joint sleeve.
15. After installing the propeller shaft, apply black paint to the exposed machined surface of the differential companion flange (Slant line section in the right figure) as a rust preventive measure.
16. Tighten the transmission under cover with the four bolts.
Tightening Torque: 15.7 - 23.5 N·m (1.6 - 2.4 kgf·m)
17. Jack down the vehicle.

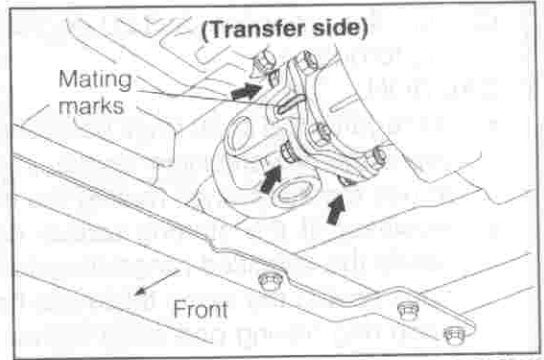

WRE91-PR063

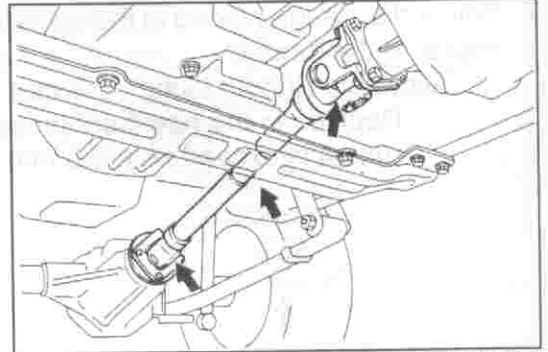

WRE91-PR064

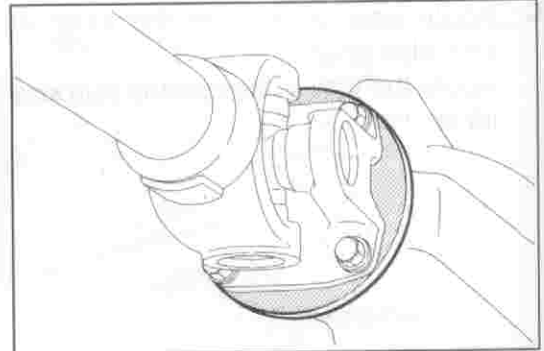

WRE91-PR065

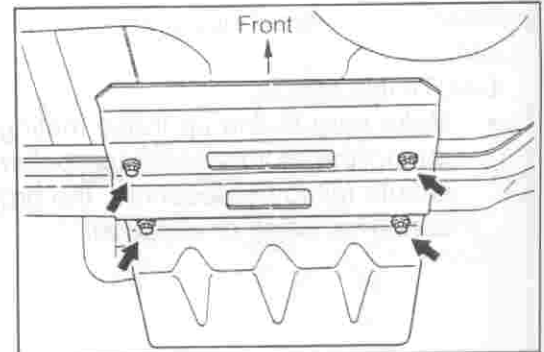

WRE91-PR100

REAR PROPELLER SHAFT

The rear propeller shaft employs a two-joint type. Furthermore, the universal joint spiders adopt an outer snap ring as its securing method.

WRE91-PR066

SECTIONAL VIEW

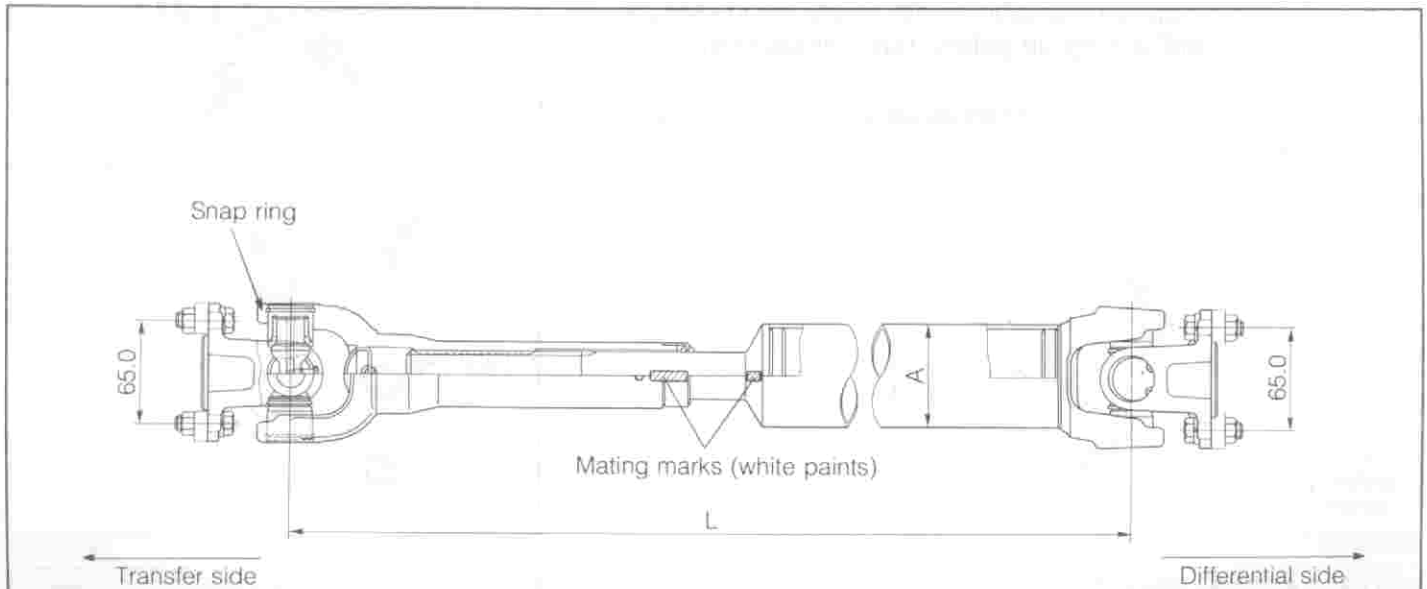

Unit: mm

MODEL	Type of transmission	Joint to joint interval (L) × Outer dia. (A)	Kinds of engine (only for diesel)
F70 (Short wheel base)	4-speed	721 × 65	Natural aspiration
	5-speed	617 × 65	
	5-speed	617 × 75	Turbo charger
F75 (Long wheel base)	4-speed	1046 × 65	Natural aspiration
	5-speed	942 × 65	Turbo charger
	5-speed	942 × 75	
F77 (Long wheel base)	4-speed	1318 × 75	Natural aspiration
	5-speed	1213 × 75	

WRE91-PR067

TROUBLE SHOOTING

Symptom	Possible causes	Checking points
Abnormal noise Vibration	<ul style="list-style-type: none"> • Universal joint improperly lubricated • Damage of universal joint spider section • Runout or damage of propeller shaft • Imbalance of propeller shaft 	<ul style="list-style-type: none"> • Lubrication to grease nipples • Check universal joints. • Check propeller shaft for runout. • Check mating marks that were put during installation or removal.

WRE91-PR068

PROPELLER SHAFTS

REPLACEMENT OF PROPELLER SHAFT WITH NEW ONE (REAR)

REMOVAL

1. Jack up the vehicle.

NOTE:

- Be sure to support the vehicle with safety stands securely (As for the jacking up points, refer GI-section)

2. Remove the rear propeller shaft assemble by removing the four bolts.

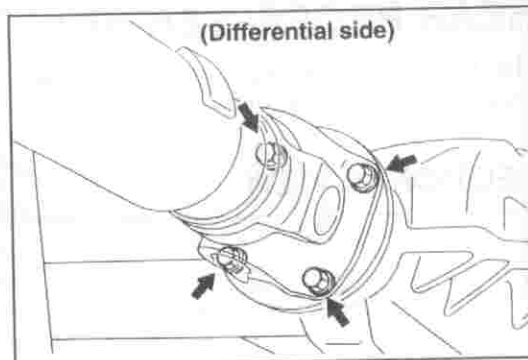

WRE91-PR069

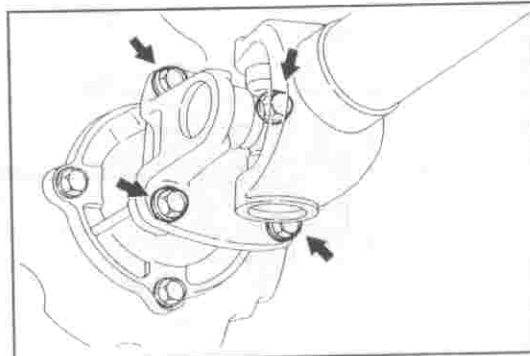

WRE91-PR070

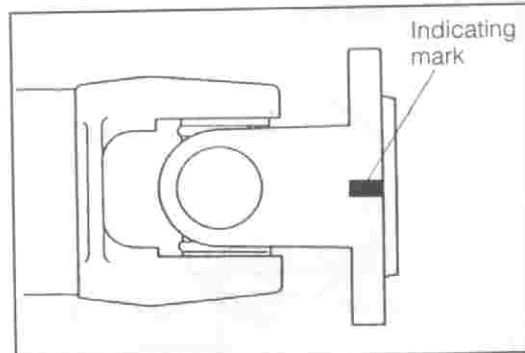

WRE91-PR071

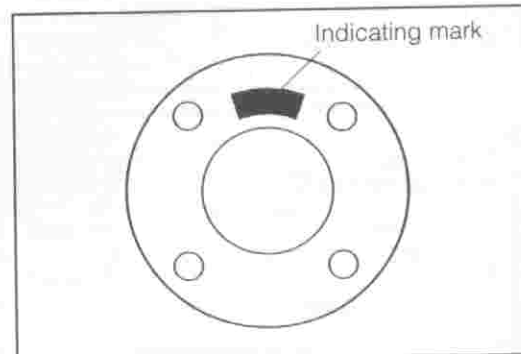

WRE91-PR072

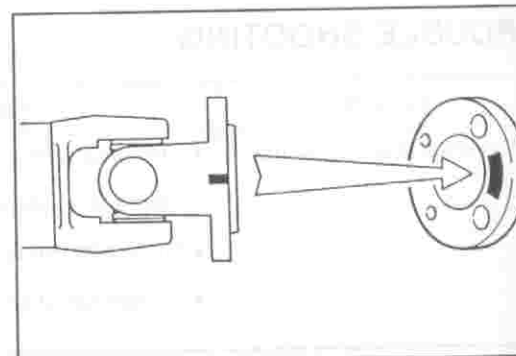

WRE91-PR073

INSTALLATION

1. Confirm the installation indicating mark (painted with white) on the rear differential attaching surface of the front propeller shaft.

2. Confirm the installation indicating mark (painted with pink) on the propeller shaft attaching surface of the rear differential companion flange.

3. Install the propeller shaft in such a way that the installation indicating mark of the rear propeller shaft may be lined up with the installation indicating mark of the rear differential companion flange.

CAUTION:

- Prior to the removal, mating marks should be put on each of the flange yoke and companion flange of the rear differential.
- If this operation should fail to be performed correctly, the propeller shaft may emit abnormal noise or vibration.

- Install the rear propeller shaft assembly with the four bolts, four spring washers, four nuts and then, tighten the bolts.
Tightening Torque: 58.8 - 78.5 N·m (6.0 - 8.0 kgf·m)

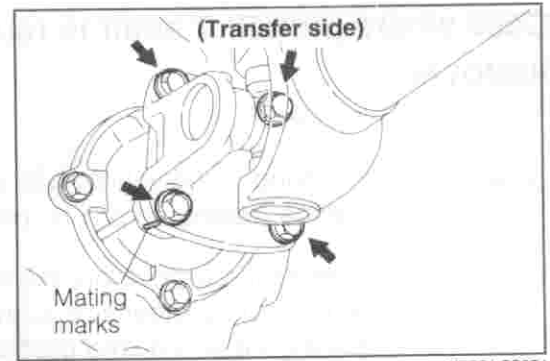

WRE91-PR074

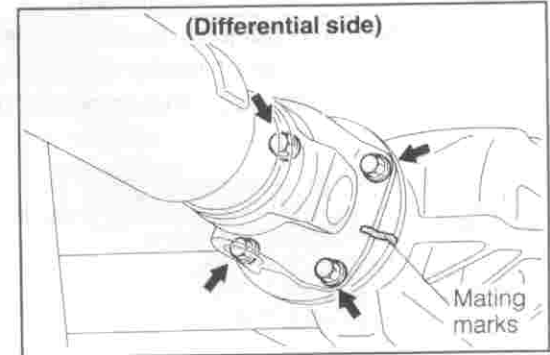

WRE91-PR075

- After installing the propeller shaft, apply black paint to the exposed machined surface of the differential (slant line section in the right figure) as a rust preventive measure.
- Fill new lithium multi-purpose grease into each grease nipple (at three points) by means of a grease gun or the like, until all existing grease is oozed out from the universal joint spider and universal joint sleeve.

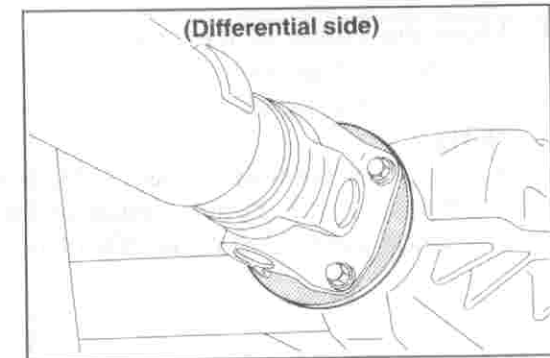

WRE91-PR101

PROPELLER SHAFTS

Case where propeller shaft is reused

REMOVAL

1. Jack up the vehicle.

NOTE:

- Be sure to support the vehicle with safety stands securely. (As for the jacking up points, refer GI-section).
2. Fill new lithium multi-purpose grease into each grease nipple (at three points) by means of a grease gun or the like, until all existing grease is oozed out from the universal joint spider and universal joint sleeve.
 3. Check the universal joint sleeve spline for excessive looseness by turning the propeller shaft in one direction and the universal joint sleeve in the opposite direction.

4. Move the center of the propeller shaft in up-&-down and right-&-left directions so as to check the universal joint spider for excessive play by hand feeling.

NOTE:

- If the universal joint spider exhibits abnormal looseness, measure the starting torque of the universal joint with flange yoke. (See page PR-14.)
5. Remove the rear propeller shaft by removing the four bolts both at the rear differential side and at the transfer side.

CAUTION:

- Prior to the removal, mating marks should be put on each of the flange yoke and companion flange of the front differential.
- If this operation should fail to be performed, the propeller shaft may emit abnormal noise or vibration during the running.

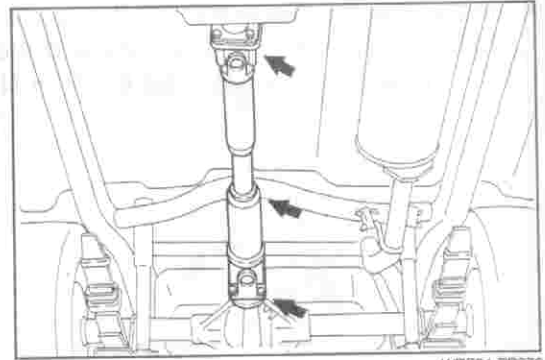

WRE91-PR076

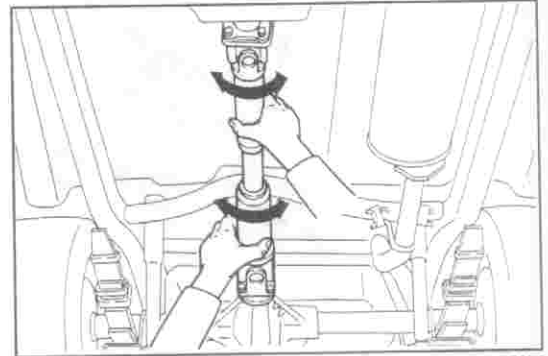

WRE91-PR077

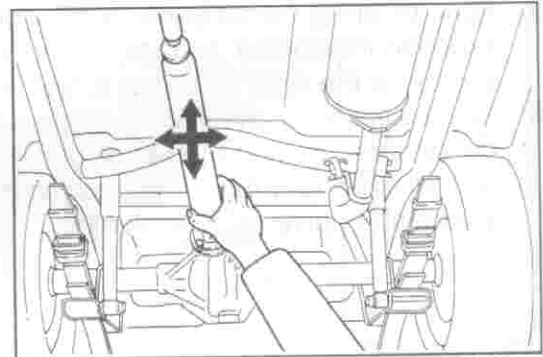

WRE91-PR078

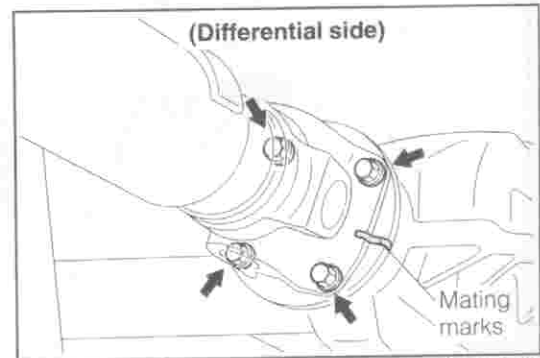

WRE91-PR079

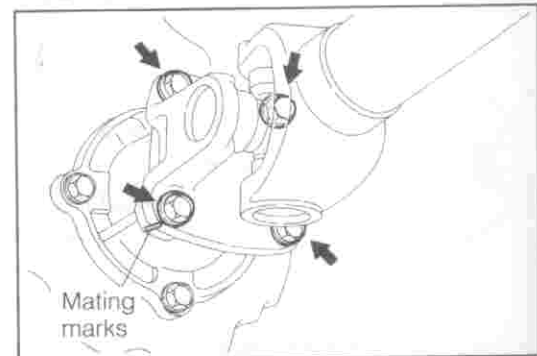

WRE91-PR080

INSPECTION

1. Measure the runout with a dial gauge set to the center of the propeller shaft.

Allowable Runout: 0.5 mm

Replace the new propeller shaft, if the runout is exceed than 0.5 mm

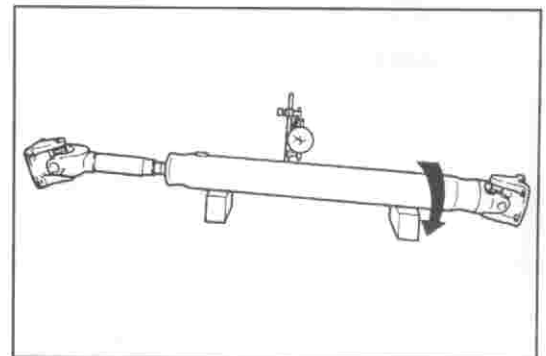

WRE91-PR081

2. Check the oil seal of the universal joint spider section for damage.

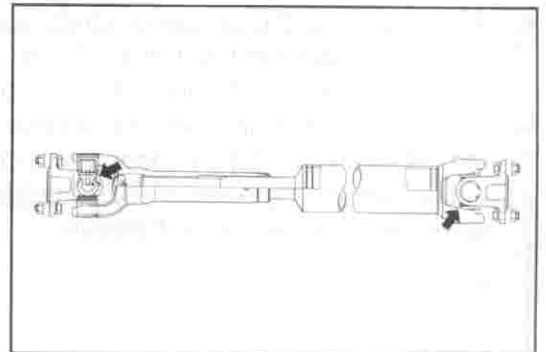

WRE91-PR082

3. Check the flange yoke and sleeve yoke.
 - (1) Inspect to see if any damage is present at the differential drive pinion companion flange-contact section ①.
 - (2) Check the oil seal sliding section ② for damage or wear.
 - (3) Check the spline ③ for damage or wear.
 - (4) Fit the sleeve yoke onto the sliding spline of the transmission output shaft. Ensure that the spline exhibits no looseness in the rotation direction and the sleeve can slide freely in the axial direction on the spline.



WRE91-PR083

INSTALLATION

1. Apply gear oil to both the inner and outer sides of the propeller shaft.
2. Apply lithium base multi purpose grease to the oil seal lip section.

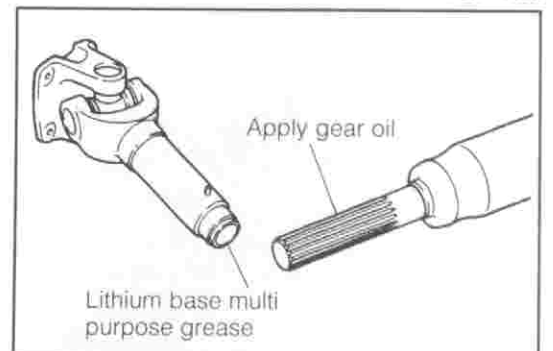

WRE91-PR084

3. Install the rear propeller shaft assembly with the four bolts, four spring washers, four nuts then, tighten the nuts.
Tightening Torque: 58.8 - 78.5 N·m (6.0 - 8.0 kgf·m)

CAUTION:

- Make sure to line up those scribing lines that were put during the removal of the rear propeller shaft. If this caution should fail to be observed, the propeller shaft may emit abnormal noise or vibration.

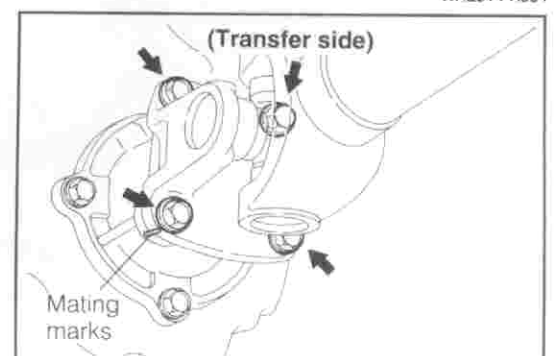

WRE91-PR085

PROPELLER SHAFTS

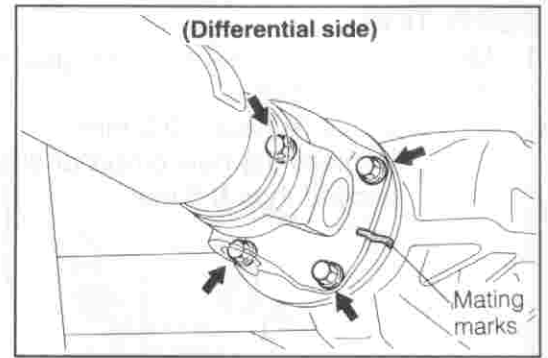

WRE91-PR086

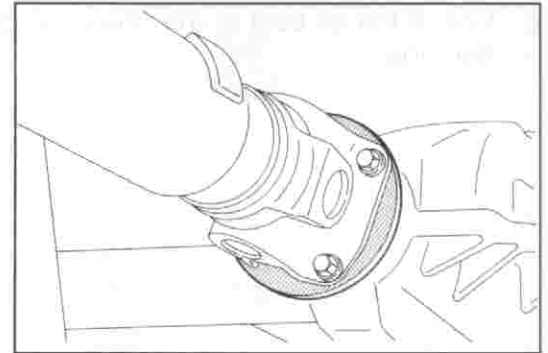

WRE91-PR102

4. After installing the propeller shaft, apply black paint to the exposed machined surface of the differential (slant line section in the right figure) as a rust preventive measure.
5. Fill new lithium multi-purpose grease into each grease nipple (at three points) by means of a grease gun or the like, until all existing grease is oozed out from the universal joint spider and universal joint sleeve.

SSTs

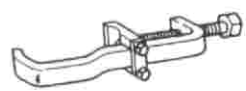
Shape	Parts No.	Parts Name
	09520-87604-000	Puller universal joint
	09956-00010-000	Tightening piece

WRE91-PR087

SERVICE SPECIFICATIONS

Unit: mm

Item	Specified value	Allowable limit	Remarks
Propeller shaft (runout)	—	0.5	Front, rear
Yoke (Inner diameters)	Sleeve	$28.0^{+0}_{-0.021}$	Using an inner dial gauge
	Flange	$28.0^{+0}_{-0.021}$	
Universal joint spider (Starting torque)	0.05 - 1.47 N·m (0.005 - 0.15 kgf·m)	—	Using a spring scale or the like

WRE91-PR088

TIGHTENING TORQUE

Tightening components	Tightening torque		
	N·m	kgf·m	ft·lb
Front propeller shaft × Differential companion flange	58.8 - 78.5	6.0 - 8.0	43.4 - 57.9
Rear propeller shaft × Differential companion flange	58.8 - 78.5	6.0 - 8.0	43.4 - 57.9

WRE91-PR089