

DAIHATSU
F70, F75, F77

**Service
manual**

LUBRICATION SYSTEM

DAIHATSU MOTOR CO., LTD.

NO.9703-FE

LU

LUBRICATION SYSTEM OUTLINE

DAIHATSU

F70, F75, F77

LUBRICATION SYSTEM

TRUBLE SHOOTING	LU- 2
LUBRICATION SYSTEM OUTLINE	LU- 3
OIL PRESSURE CHECK	LU- 5
ENGINE OIL CHANGE & OIL FILTER REPLACEMENT	LU- 7
OIL PUMP	LU- 9
OIL FILTER & OIL FILTER BRACKET	LU-13
SST (Special Service Tools)	LU-17
TIGHTENING TORQUE	LU-17
SERVICE SPECIFICATION	LU-18

WRE91-LU001

LUBRICATION SYSTEM

TROUBLE SHOOTING

Problem	Possible causes	Remedies	Page
Oil leakage	Cylinder head, Cylinder block oil cooler, oil pump body damaged or cracked	Repair, if necessary.	LU-3
	Oil seal faulty	Replace oil seal.	
	Gasket faulty	Replace gasket.	
Low oil pressure	Oil leakage	Repair, as necessary.	LU-3
	Relief valve faulty	Replace relief valve.	
	Oil pump faulty	Repair oil pump.	LU-9
	Poor quality engine oil	Change engine oil.	LU-5
	Crankshaft bearing faulty	Replace bearing.	LU-7
	Connecting rod bearing faulty	Replace bearing.	
	Oil filter clogged	Replace oil filter.	
	Low oil level	Check oil level.	
High oil pressure	Relief valve faulty	Replace relief valve.	LU-10
Poor engine oil	Oil leakage	Repair, as necessary.	LU-3
Consumption	Relief valve faulty	Replace relief valve.	

WRE91-LU002

LUBRICATION SYSTEM OUTLINE

The lubrication system employs a fully-forced feed, filtering method.

The oil stored in the oil pan is sucked by an oil pump which is directly driven by the crankshaft. Then, the thus-sucked oil flows through an oil pump strainer and is filtered at an oil filter. After having passed through the passages of the cylinder block, it will be divided into two streams so as to lubricate various sections.

One stream of the lubrication oil performs lubrication of various sections of the crankshaft and connecting rod- and piston-related parts. The other stream of the lubrication, oil rises to the cylinder head section. Then, it performs lubrication of valve rocker shaft-related parts.

WRE91-LU003

Lubrication System Schematic Diagram

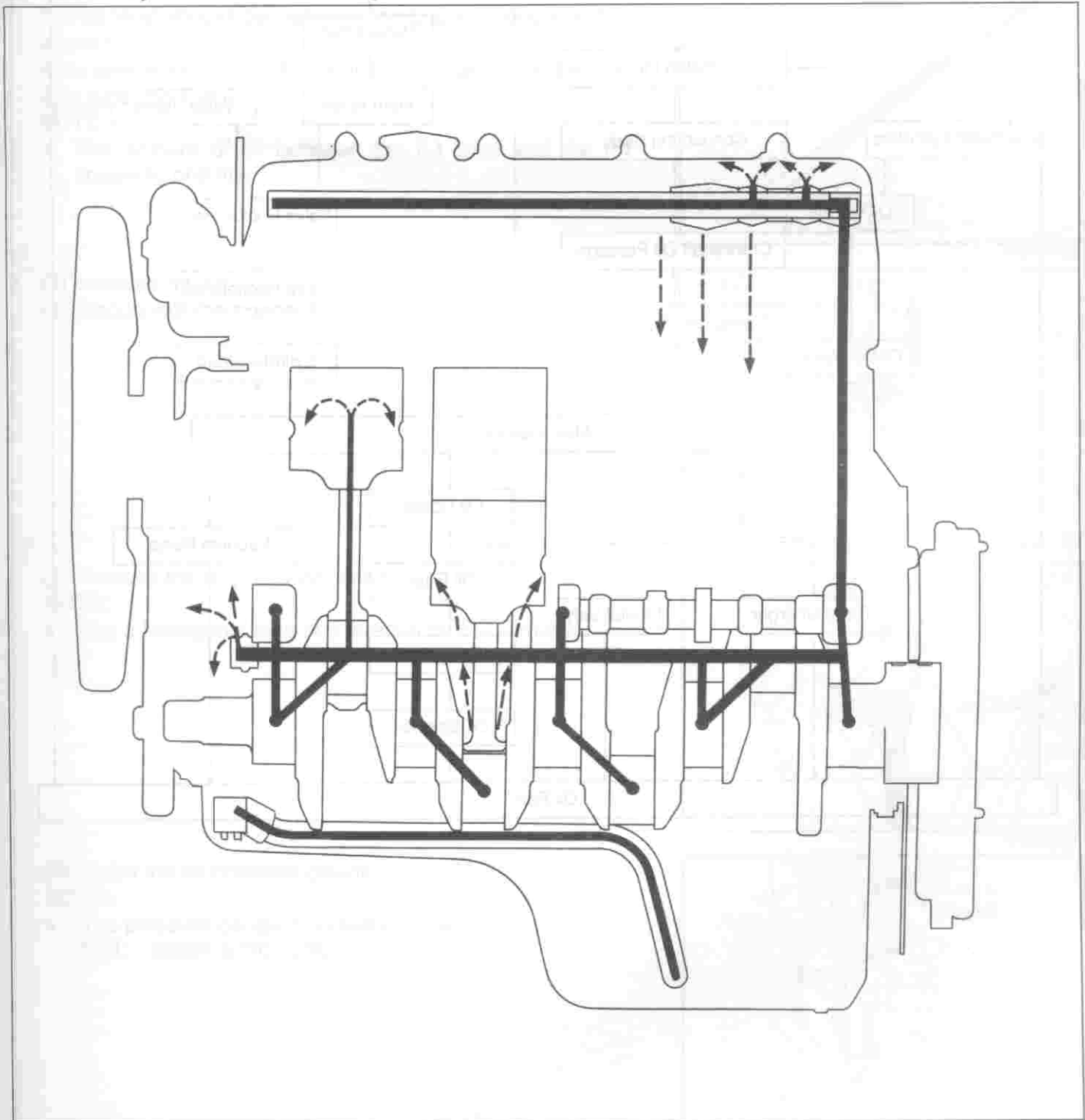

WRE91-LU004

LUBRICATION SYSTEM

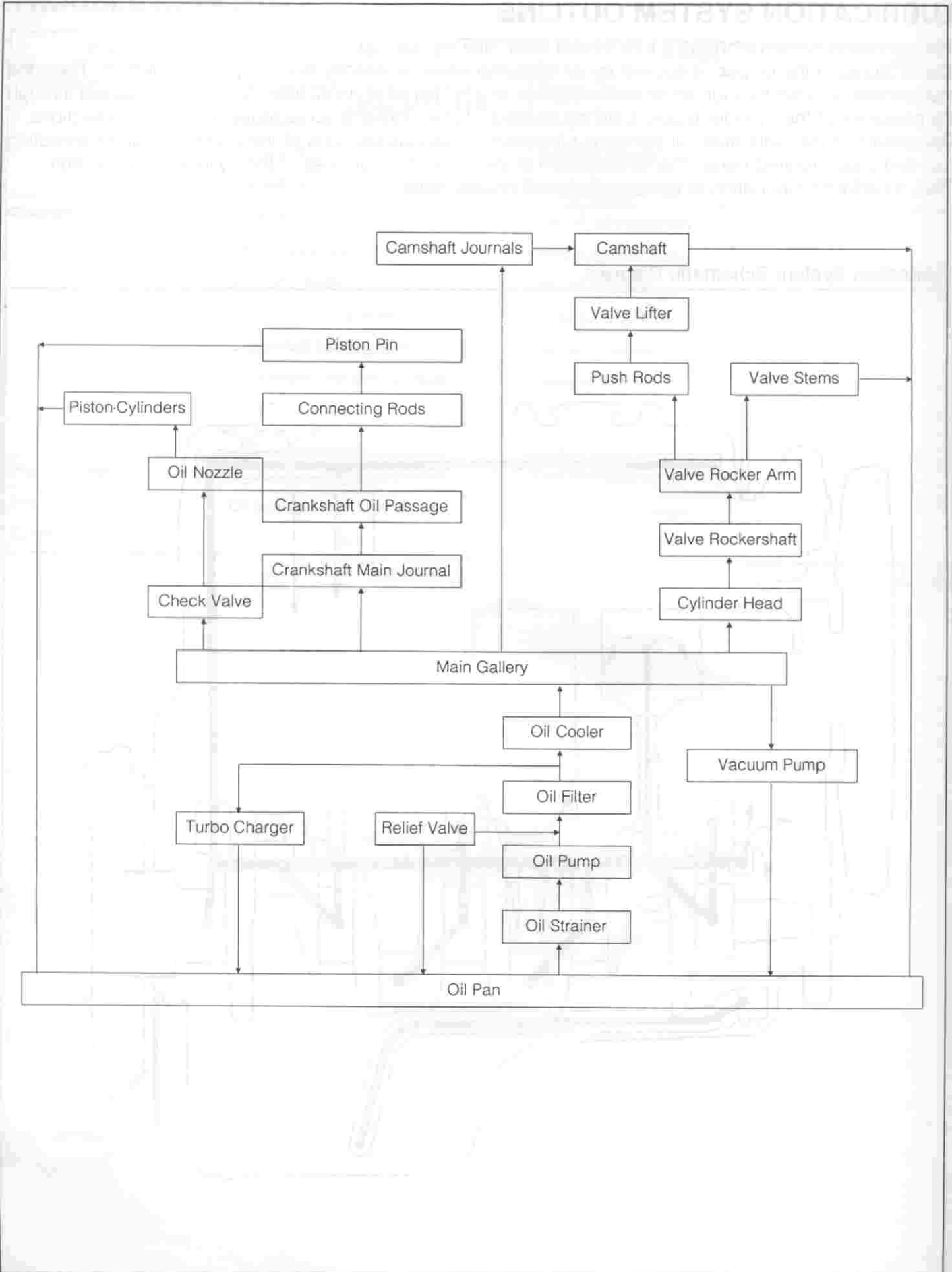

WRE91-LU005

OIL PRESSURE CHECK

1. Oil quality check

Check the oil for deterioration, ingress of water, discoloring or dilution.

If oil quality is poor, change the oil.

Use API grade CC, CD multigrade viscosity, fuel-efficient oil. (See page LU-8.)

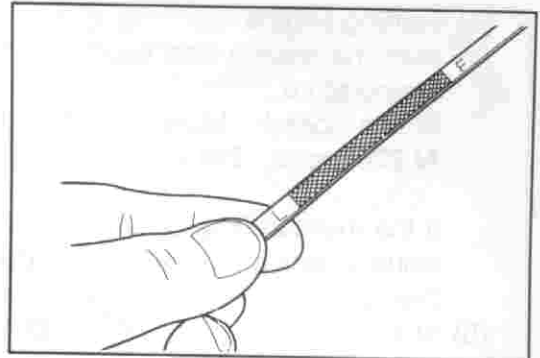

WRE91-LU006

2. Oil level check

The oil level should be between the L and F levels on the dipstick.

If the level is low, check to see if any oil leakage is present.

Add oil to the F level.

NOTE:

- The amount of oil between the [L] level and the [F] equals to one liter.

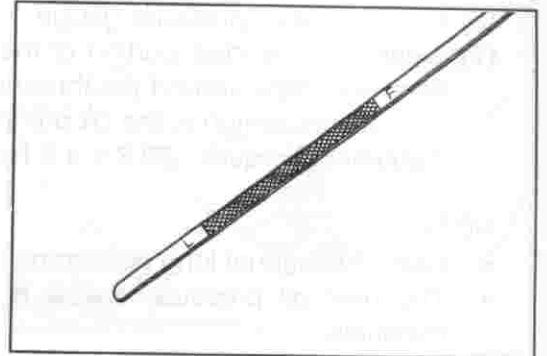

WRE91-LU007

3. Oil pressure check

- (1) Disconnect the connector of oil pressure switch.

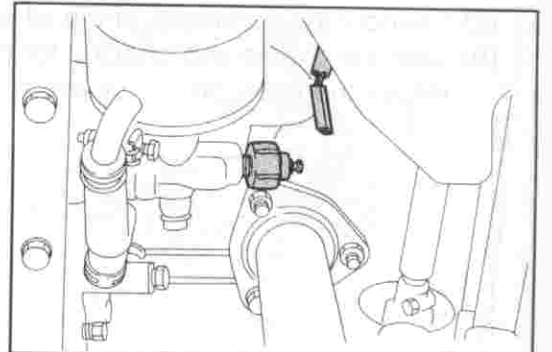

WRE91-LU008

- (2) Remove the oil pressure switch.

NOTE:

- Use a hexagonal long box wrench for the removal.

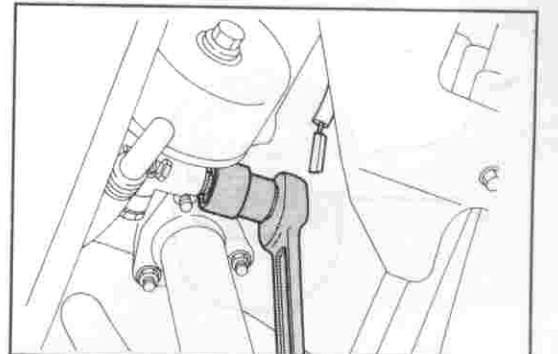

WRE91-LU009

- (3) Install the oil pressure gauge.

NOTE:

- The pressure gauge is available as a SST.
SST: 09268-87701-000

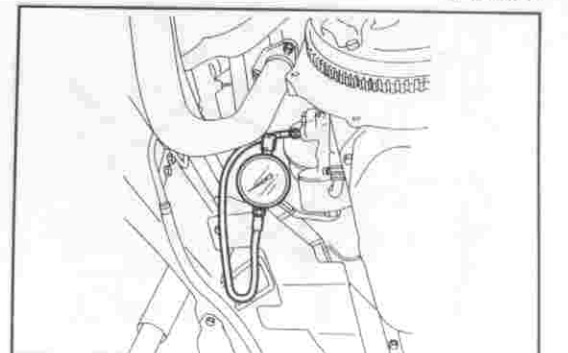

WRE91-LU010

LUBRICATION SYSTEM

(4) Starting engine

Start the engine and warm it to the normal operating temperature.

At Idle Speed: More than 19.6 kPa (0.2 kgf/cm²)

At 2200 rpm: 294.2 - 392.3 kPa (3.0 - 4.0 kgf/cm²)

If the measured value fails to conform to the specified value, check and repair the oil pump.

(See page LU-9.)

(5) Stop the engine.

(6) Remove the oil pressure gauge.

(7) Clean the threaded portion of the oil pressure switch. Wind seal tape around the threaded portion. Install the oil pressure switch in the oil pump.

Tightening Torque: 39.2 ± 4.9 N·m (4.0 ± 0.5 kgf·m)

NOTE:

- Use a hexagonal long box wrench for the installation.
- The new oil pressure switch is coated with sealing materials.

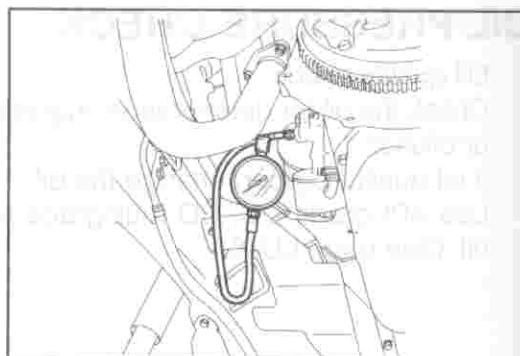

WRE91-LU011

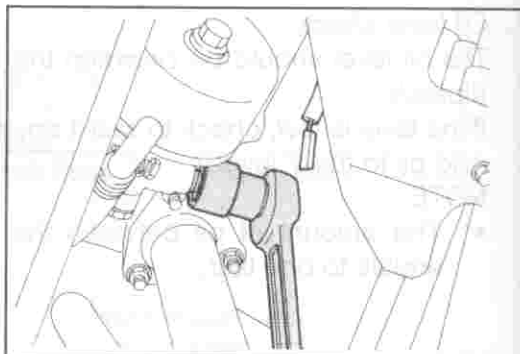

WRE91-LU012

(8) Connect the connector of the oil pressure switch.

(9) Start the engine and check it for oil leakage.

Repair the leaky point if oil leakage exists.

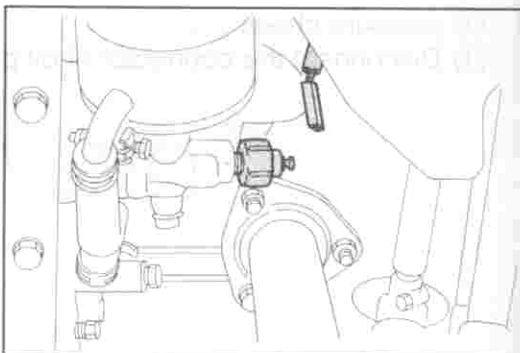

WRE91-LU013

ENGINE OIL CHANGE & OIL FILTER REPLACEMENT

1. Drain the engine oil as follows:
 - (1) Place a suitable container under the oil drain plug.
 - (2) Remove the engine under cover.
 - (3) Drain the oil by removing the oil drain plug.

WARNING:

- When the oil is still hot, care must be exercised to avoid getting scalded.

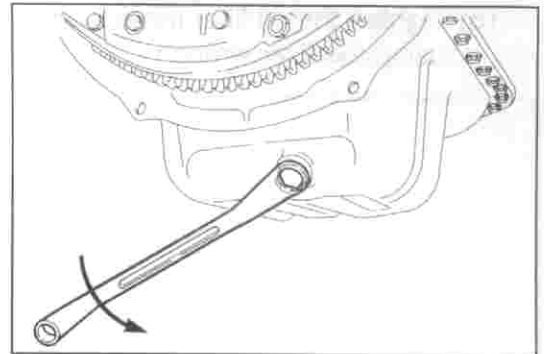

WRE91-LU014

2. Oil filter replacement
 - (1) Remove the oil filter element, using the filter wrench.

NOTE:

- Place a suitable container under the oil filter because the engine oil flows out.

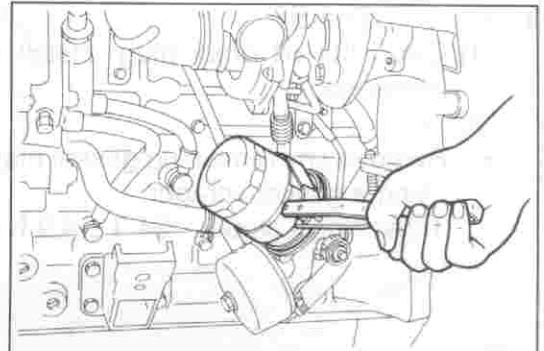

WRE91-LU015

- (2) Inspect and clean the oil filter installation surface.

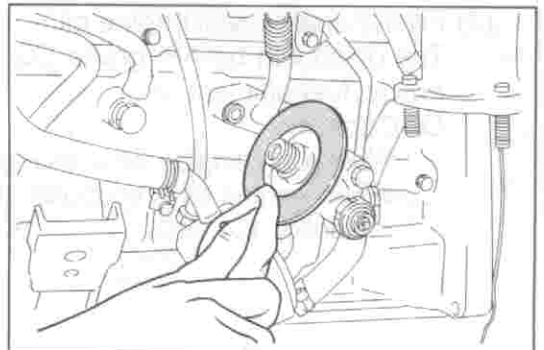

WRE91-LU016

- (3) Thinly apply engine oil to the "O" ring of a new oil filter.

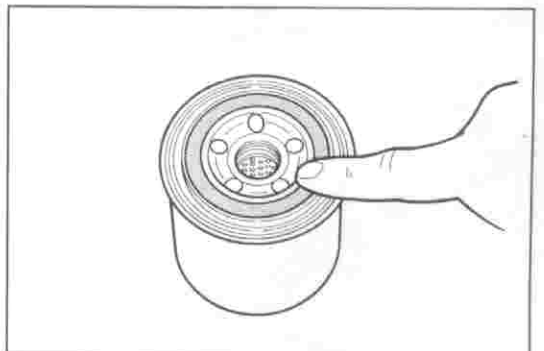

WRE91-LU017

- (4) Screw in the oil filter by hand, until the "O" ring of the oil filter contacts the oil filter installing surface.

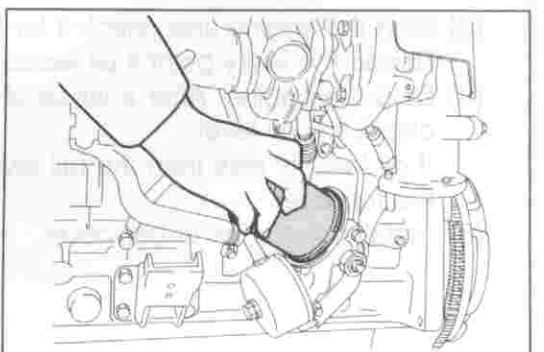

WRE91-LU018

LUBRICATION SYSTEM

- (5) Tighten the oil filter three fourths to one complete turn, using the filter wrench.

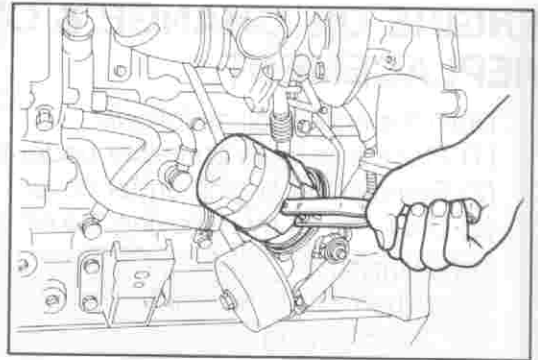

WRE91-LU019

3. Filling engine oil

- (1) Clean the oil drain plug. Install it with a new gasket interposed.

NOTE:

- Remove any remaining gasket material from the oil pan, using a gasket scraper.

Tightening Torque: 34.3 ± 4.9 N·m (3.5 ± 0.5 kgf·m)

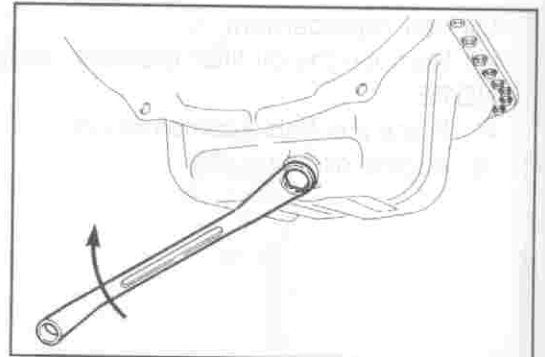

WRE91-LU020

- (2) Fill the engine with engine oil.
The oil should be API grade CC or CD multigrade viscosity, fuel-efficient oil.

Oil Capacity:

When only engine oil is changed: 5.8 dm^3

When engine oil is changed and oil filter is replaced: 6.4 dm^3

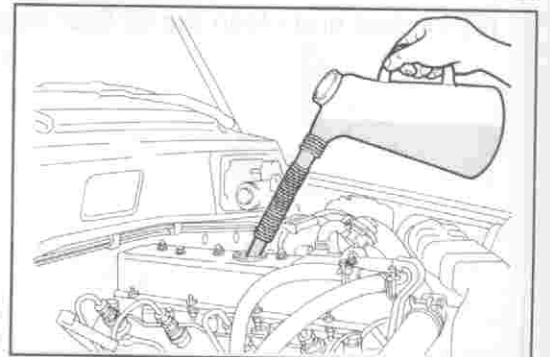

WRE91-LU021

Recommended engine oil viscosity (SAE)

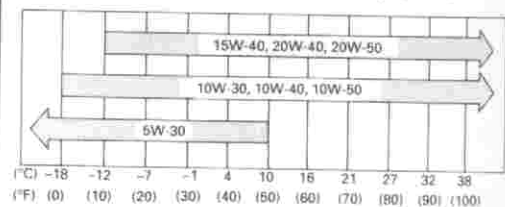

Atmosphere temperature range anticipated before next oil change

WRE91-LU022

- (3) Start the engine and check it for leakage.
Repair the leaky point if oil leakage exists.
- (4) Stop the engine. After a lapse of two or three minutes, check the oil level.
If oil level is less than the full level, replenish the oil to the full level.
- (5) Install the engine under cover.

WRE91-LU023

OIL PUMP COMPONENTS

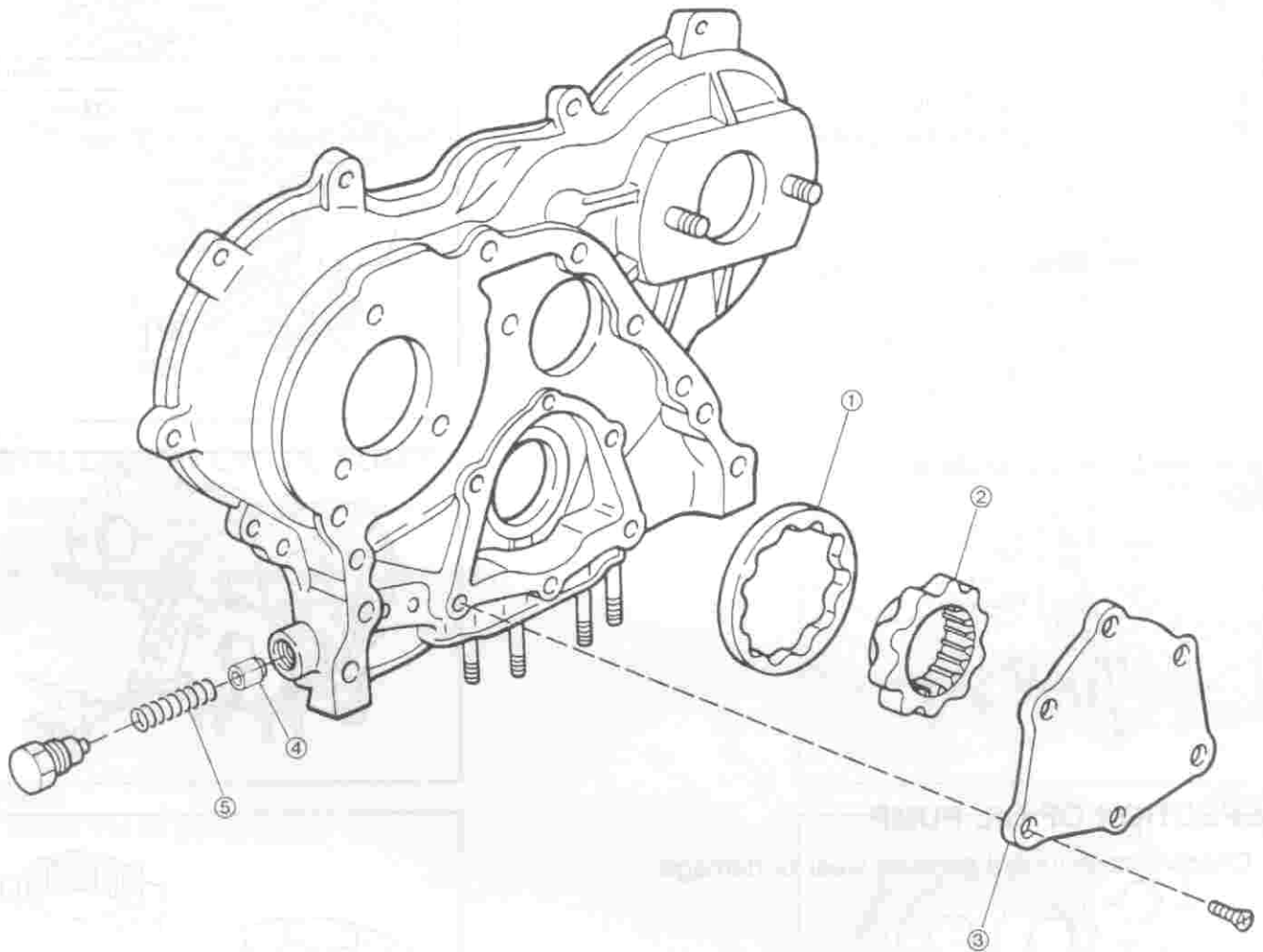

- ① Driven gear
- ② Drive gear
- ③ Oil pump plate
- ④ Relief valve
- ⑤ Spring

LUBRICATION SYSTEM

REMOVAL OF OIL PUMP

* After the timing belt cover and case have been removed, proceed to the following operation.

1. Remove the oil pan.
2. Remove the oil pump pipe.
3. Remove the timing belt case.
4. Remove the timing belt case gasket.

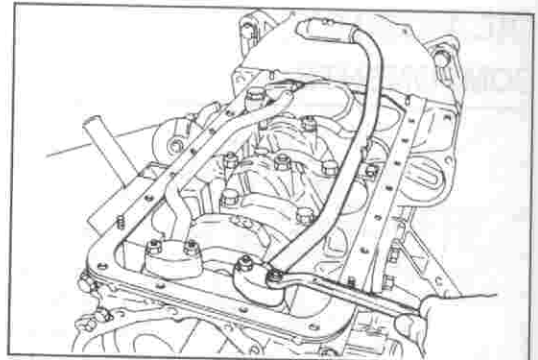

WRE91-LU025

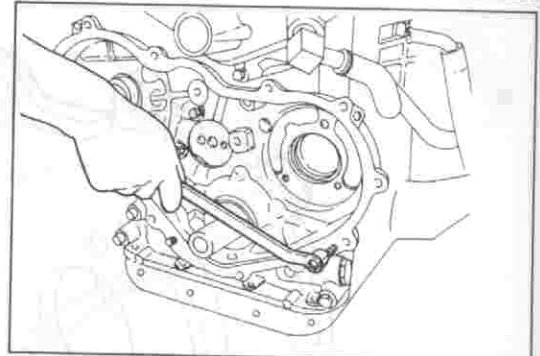

WRE91-LU026

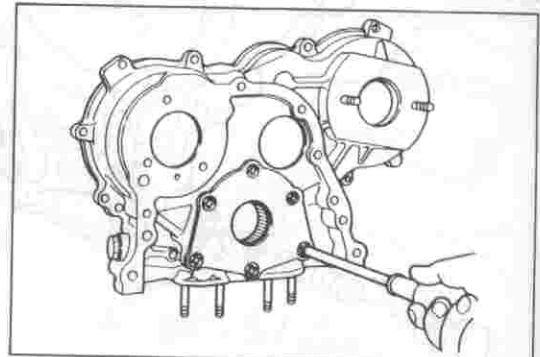

WRE91-LU027

5. Remove the oil pump plate.

INSPECTION OF OIL PUMP

1. Check disassembled parts for wear or damage.

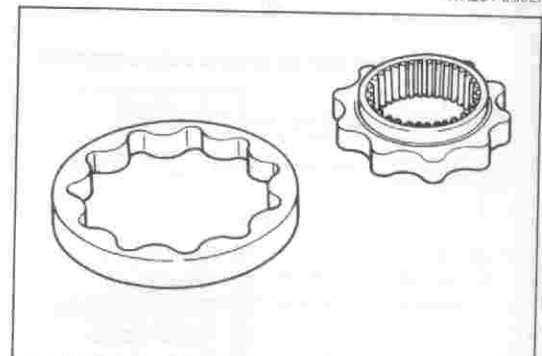

WRE91-LU028

2. Check the relief valve for wear or damage.

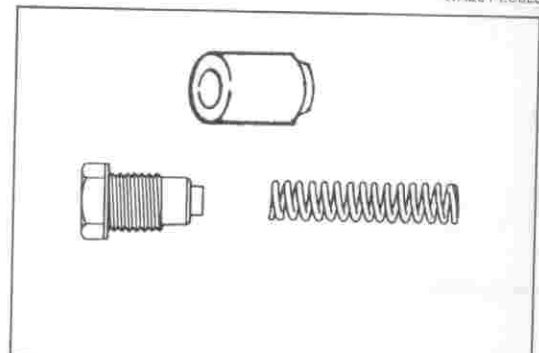

WRE91-LU029

3. Measure the body clearance.
Body Clearance: Limit 0.4 mm

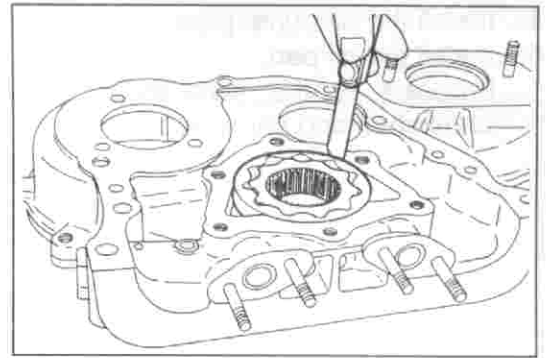

WRE91-LU030

4. Measure the side clearance.
Side Clearance: Limit 0.15 mm

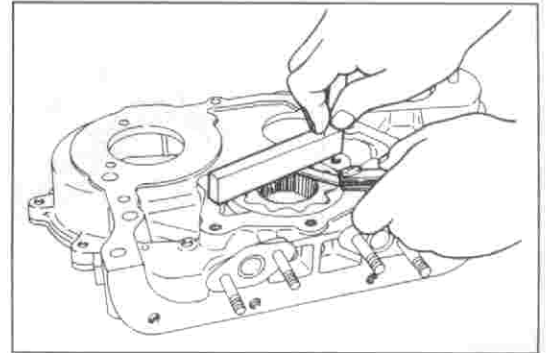

WRE91-LU031

INSTALLATION OF OIL PUMP

1. Install the timing belt case gasket.
NOTE:
 - Replace the gasket with a new one.

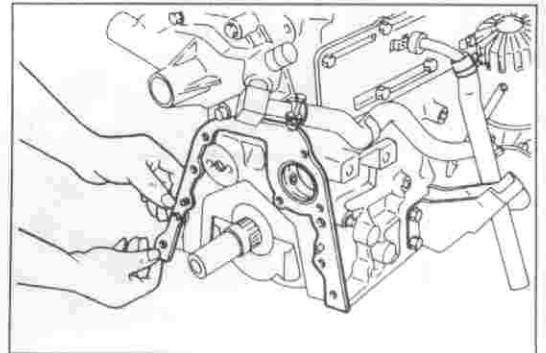

WRE91-LU032

2. Install the oil pump plate.

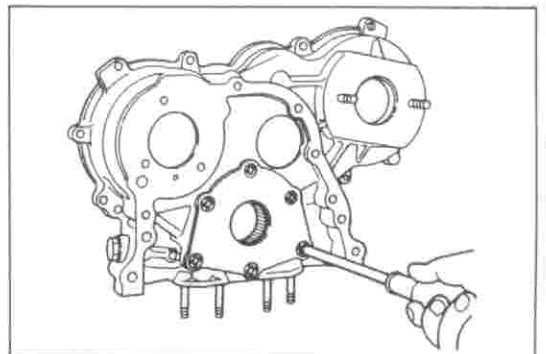

WRE91-LU033

3. Install the timing belt case.

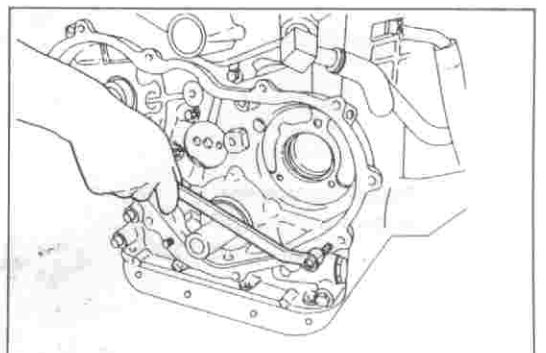

WRE91-LU034

LUBRICATION SYSTEM

4. Install the oil pump pipe.
5. Install the oil pan.
- * Proceed to the installation of the timing belt case, crankshaft and camshaft.

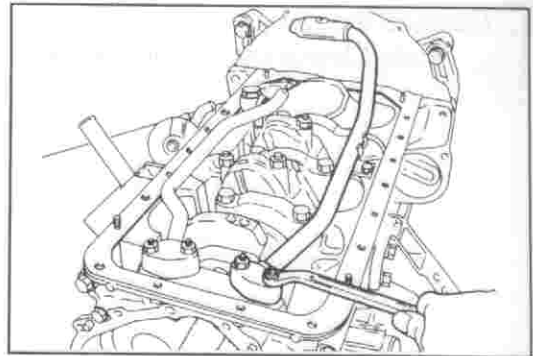

WRE91-LU035

OIL FILTER & OIL FILTER BRACKET
COMPONENTS

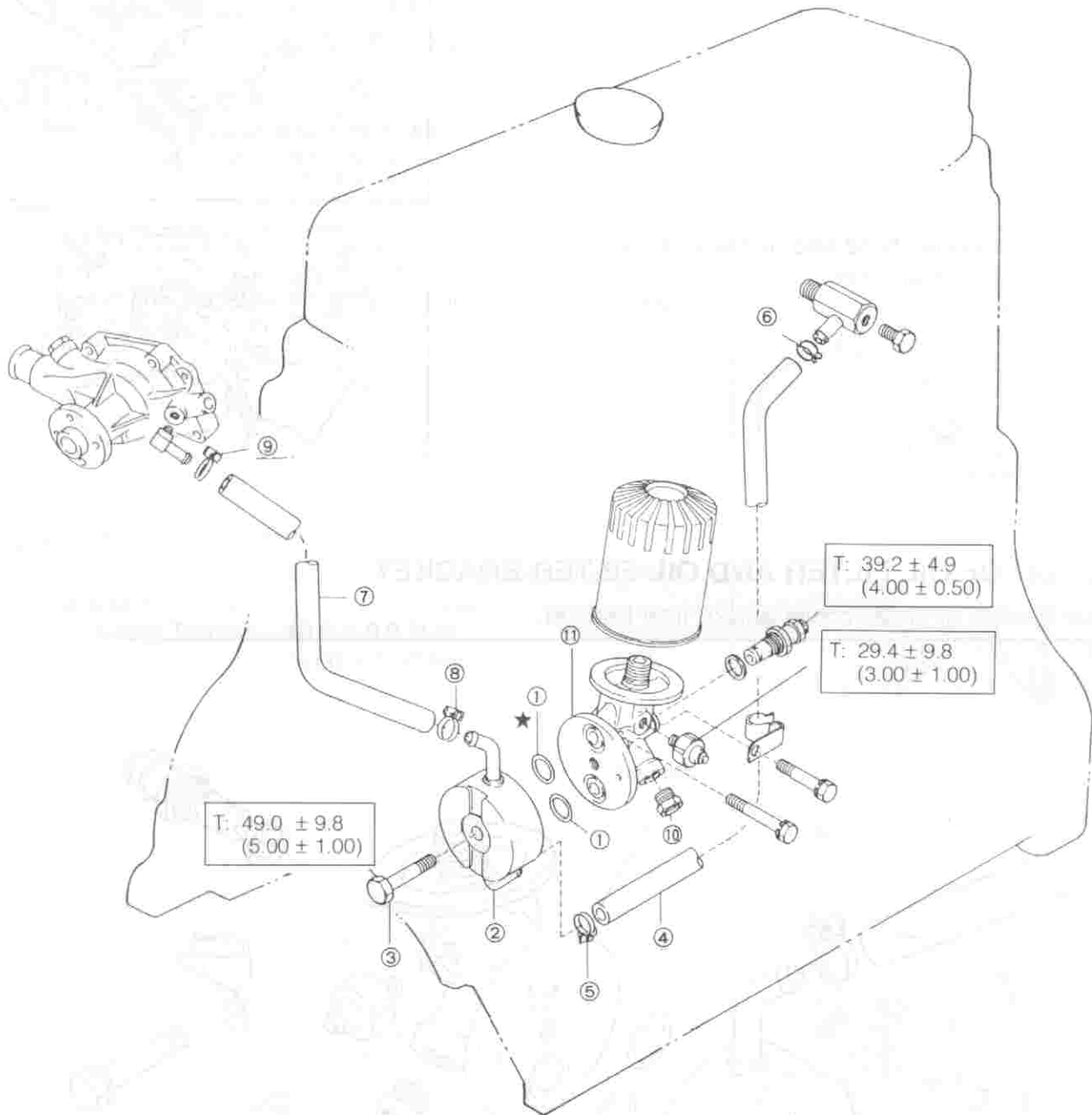

- ① "O" Ring
- ② Cooler Ay oil
- ③ Bolt
- ④ Hose, oil cooler No. 1
- ⑤ Clamp Hose
- ⑥ Clamp, Hose

- ⑦ Hose, oil cooler No. 2
- ⑧ Clamp, Hose
- ⑨ Clamp Hose
- ⑩ Plug
- ⑪ Oil filter bracket

★ : Non-reusable part
 T : Tightening torque
 Unit : N-m (kgf-m)

LUBRICATION SYSTEM

REMOVAL OF OIL FILTER AND OIL FILTER BRACKET

1. Remove the oil filter.
2. Remove the oil cooler hose and oil cooler assy.
3. Remove the oil filter bracket.

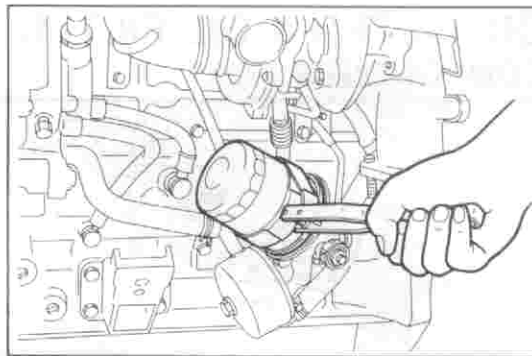

WRE91-LU037

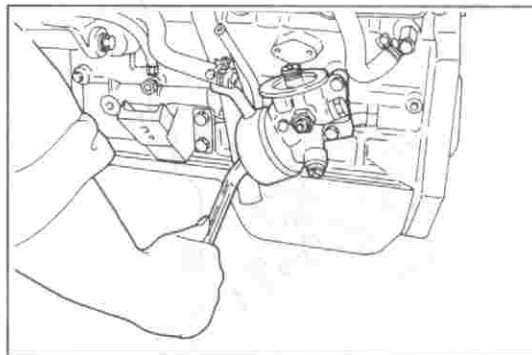

WRE91-LU038

INSPECTION OF OIL FILTER AND OIL FILTER BRACKET

Check each section of the oil cooler and oil filter bracket.

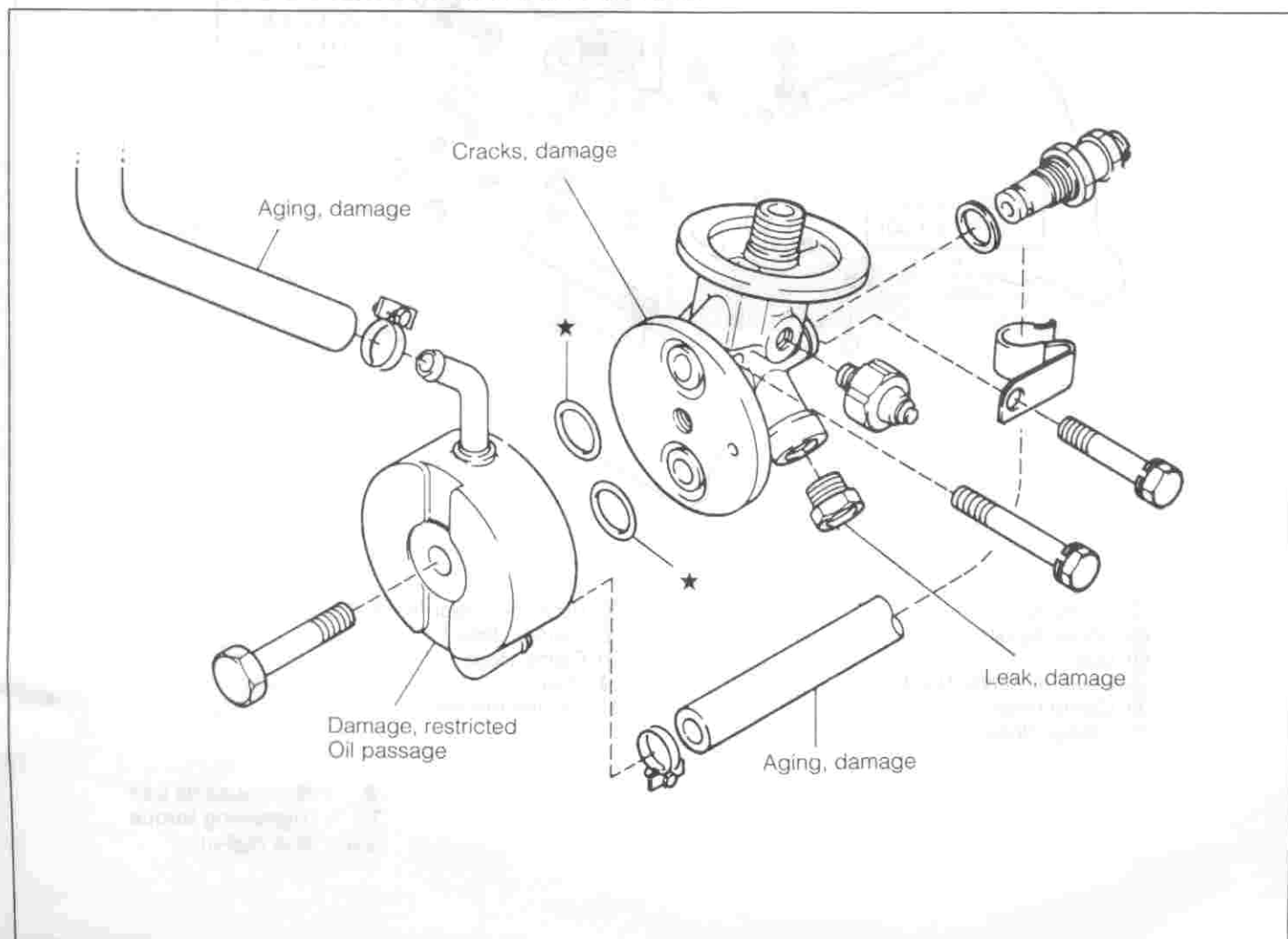

WRE91-LU039

INSTALLATION OF OIL FILTER AND OIL FILTER BRACKET

1. Install the oil filter bracket.

Tightening Torque: 36.8 ± 7.4 N·m
(3.75 ± 0.75 kgf-m)

NOTE:

- Replace the gasket with a new one.

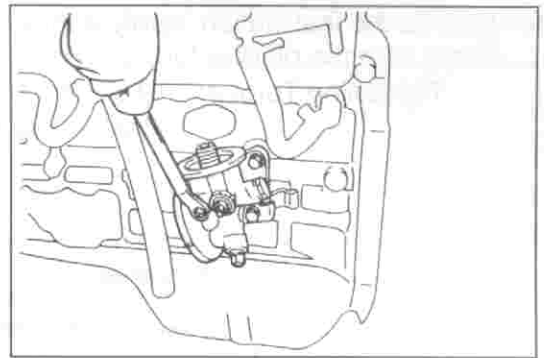

WRE91-LU040

2. Install the oil cooler to the oil filter bracket.

NOTE:

- Prior to the installation, apply engine oil to the "O" ring thinly.

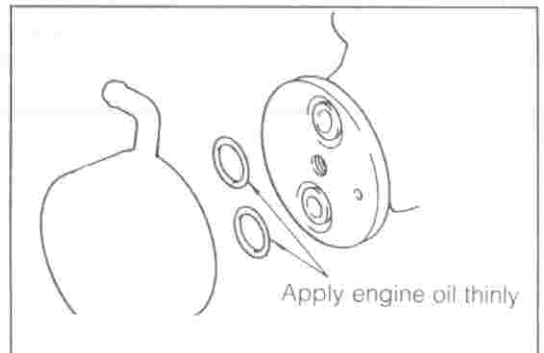

Apply engine oil thinly

WRE91-LU041

3. Install the oil cooler assembly with the knock pin aligned with its knock pin hole.

Tightening Torque: 49.0 ± 9.8 N·m
(5.00 ± 1.00 kgf-m)

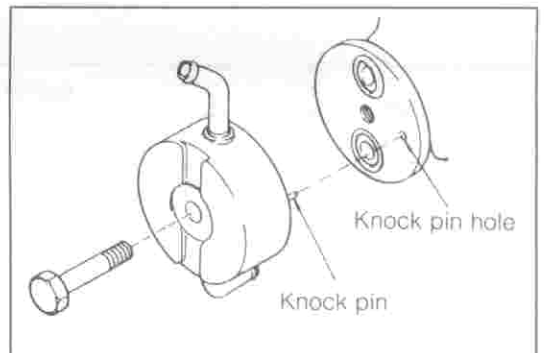

Knock pin hole

Knock pin

WRE91-LU042

4. Install the oil cooler hose No. 1 and clamp it.

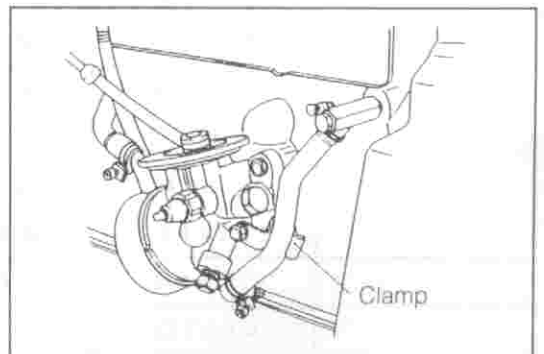

Clamp

WRE91-LU043

5. Install the oil cooler hose No. 2 and clamp it.

NOTE:

- Attach the clamp in such a direction that it may not interfere with the fan pulley.

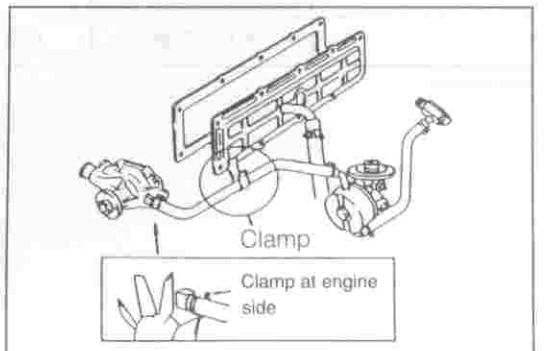

Clamp

Clamp at engine side

WRE91-LU044

LUBRICATION SYSTEM

- Prior to the installation, apply engine oil to the "O" ring. Then, turn the oil filter fully by hands.

Tightening Torque: $19.6 \pm 2.0 \text{ N}\cdot\text{m}$
($2.00 \pm 0.20 \text{ kgf}\cdot\text{m}$)

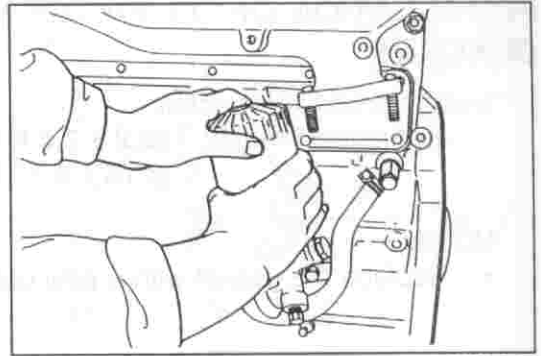

WRE91-LU045

SST (Special Service Tools)

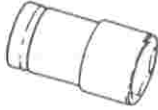
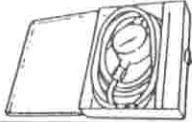
Shape	Parts No. and Name	Purpose	Remarks
	09032-00100-000 Oil pan seal cutter	Removal of oil pan	
	09268-87704-000 Oil cooler set bolt box wrench	Removal and installation of oil cooler (only for oil cooler-equipped vehicle)	Only for oil cooler-equipped vehicle
	09990-87702-000 Engine oil pressure gauge	Measurement of engine oil pressure	

WRE91-LU046

TIGHTENING TORQUE

Tightening component	Tightening torque			Remark
	N-m	kgf-m	ft-lb	
Cylinder Block × Oil pan	9.3 ± 2.5	0.95 ± 0.25	6.9 ± 1.8	
Cylinder Block × Oil hose No. 1	17.2 ± 2.5	1.75 ± 0.25	12.7 ± 1.8	
Cylinder Block × Oil hose No. 2	22.1 ± 2.5	2.25 ± 0.25	16.3 ± 1.8	
Cylinder Block × Oil pump inlet pipe	18.1 ± 3.4	1.85 ± 0.35	13.4 ± 2.5	
Cylinder Block × Oil pump outlet pipe	44.1 ± 7.4	4.50 ± 0.75	32.5 ± 5.4	
Cylinder Block × Oil pump relief plug	39.2 ± 4.9	4.00 ± 0.50	28.9 ± 3.6	
Oil filter bracket × Oil cooler	49.0 ± 9.8	5.00 ± 1.00	36.2 ± 7.2	
Oil filter bracket × Oil pressure valve	39.2 ± 4.9	4.00 ± 0.50	28.9 ± 3.6	
Oil filter bracket × Oil filter	19.6 ± 2.0	2.00 ± 0.20	14.5 ± 1.5	
Oil filter bracket × T/C oil inlet pipe	12.8 ± 2.9	1.30 ± 0.30	9.4 ± 2.2	
T/C × T/C oil outlet pipe	7.4 ± 1.5	0.75 ± 0.15	5.4 ± 1.1	
Vacuum pump × Oil hose No. 1	17.2 ± 2.5	1.75 ± 0.25	12.7 ± 1.8	
Vacuum pump × Oil hose No. 2	22.1 ± 2.5	2.25 ± 0.25	16.3 ± 1.8	
Oil pan × Drain plug	34.3 ± 4.9	3.50 ± 0.50	25.3 ± 3.6	

WRE91-LU047

LUBRICATION SYSTEM

SERVICE SPECIFICATION

Engine oil capacity		
Whole amount		
When only oil is changed	Full level	5.8 dm ³
	Low level	4.8 dm ³
When oil and filter are changed		6.4 dm ³
Oil pump	Compression spring free length	57 mm
	Body clearance	0.20 - 0.28 mm
	Tip clearance	0.16 - 0.24 mm
	Side clearance	0.035 - 0.085 mm
Oil pressure	Idling	147 - 196 kPa (1.5 - 2.0 kgf/cm ²)
	2200 rpm	294 - 392 kPa (3.0 - 4.0 kgf/cm ²)

WRE91-LU048