

DAIHATSU
F70, F75, F77

**Service
manual**

CHARGING SYSTEM

DAIHATSU MOTOR CO., LTD.

NO.9703-FE

CH

DAIHATSU

F70, F75, F77

CHARGING SYSTEM

1. COMPONENTS OF ALTERNATOR CH- 2
2. CHARGING SYSTEM CIRCUIT CH- 4
3. IN-VEHICLE INSPECTION CH- 5
4. REMOVAL OF ALTERNATOR CH- 7
5. DISASSEMBLY OF ALTERNATOR CH- 8
6. INSPECTION OF ALTERNATOR CH-10
7. ASSEMBLY OF ALTERNATOR CH-13
8. DISASSEMBLY OF
VACUUM PUMP CH-16
9. INSPECTION OF VACUUM PUMP CH-16
10. ASSEMBLY OF VACUUM PUMP CH-16
11. INSTALLATION OF ALTERNATOR ... CH-17
12. INSPECTION OF REGULATOR CH-18

WRE91-CH001

1. COMPONENTS OF ALTERNATOR

This alternator is a type in which a vacuum pump for generating negative pressure is directly connected.

(1) Alternator

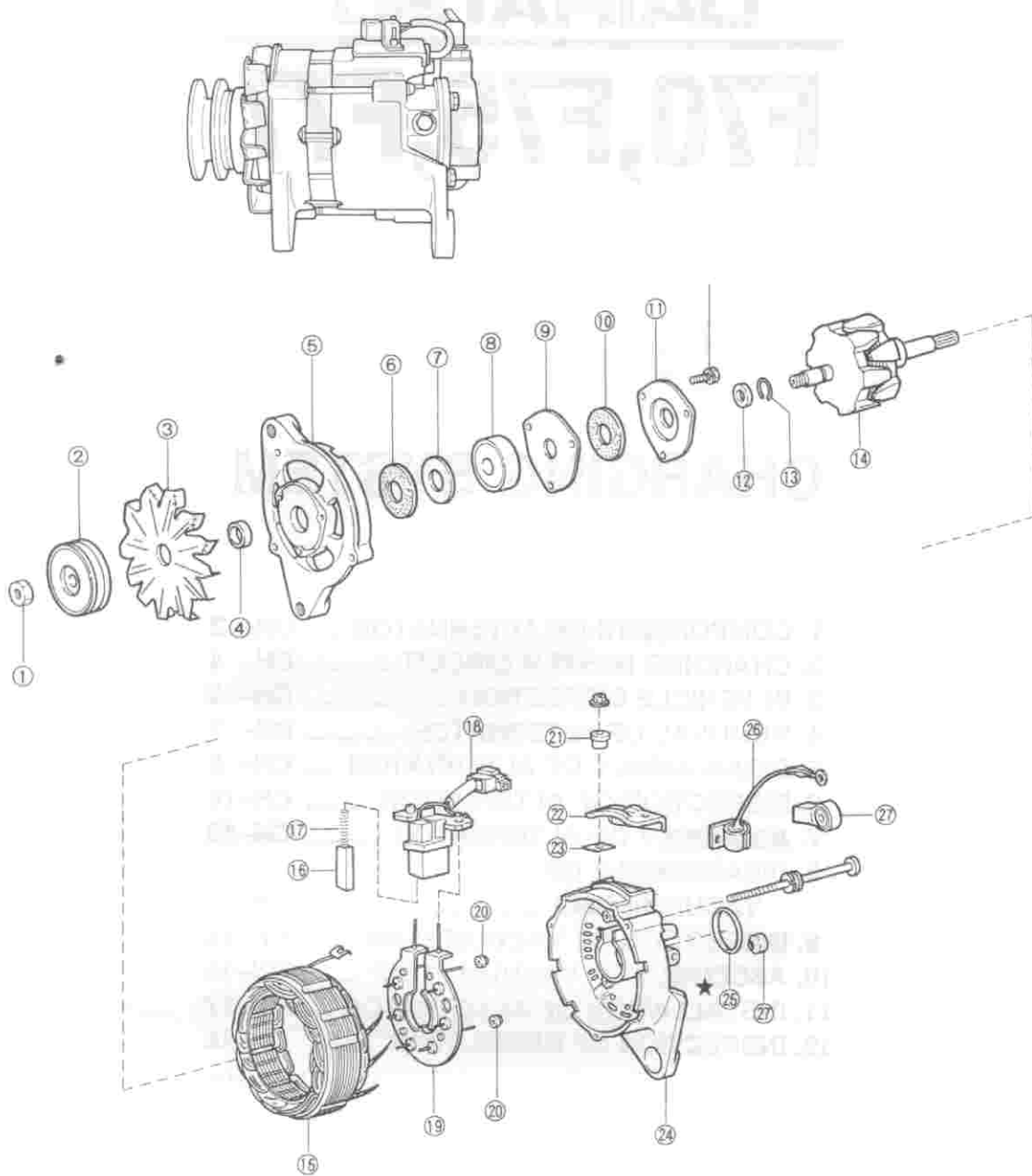

★ Non-reusable parts

- ① Pulley lock nut
- ② Pulley
- ③ Fan
- ④ Collar
- ⑤ Drive end frame
- ⑥ Felt washer
- ⑦ Felt cover
- ⑧ Bearing
- ⑨ Retainer plate
- ⑩ Felt washer
- ⑪ Felt cover
- ⑫ Spacer ring
- ⑬ Snap ring
- ⑭ Rotor

- ⑮ Stator
- ⑯ Brush
- ⑰ Spring
- ⑱ Holder
- ⑲ Rectifier holder
- ⑳ Insulator
- ㉑ Bush
- ㉒ Frame brush cover
- ㉓ Washer
- ㉔ Rear end frame
- ★ ㉕ Vacuum pump packing
- ★ ㉖ Condenser
- ㉗ Insulator

(2) Vacuum pump

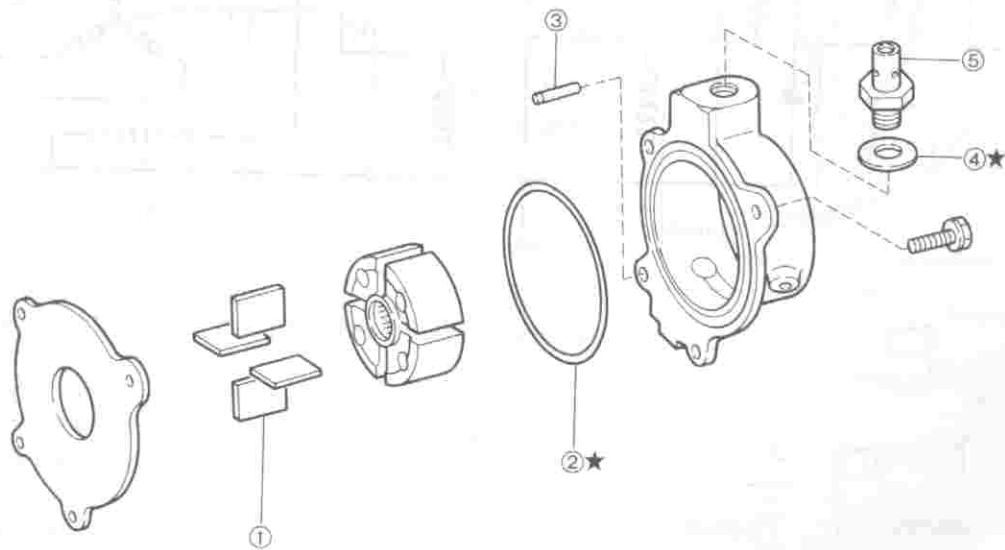
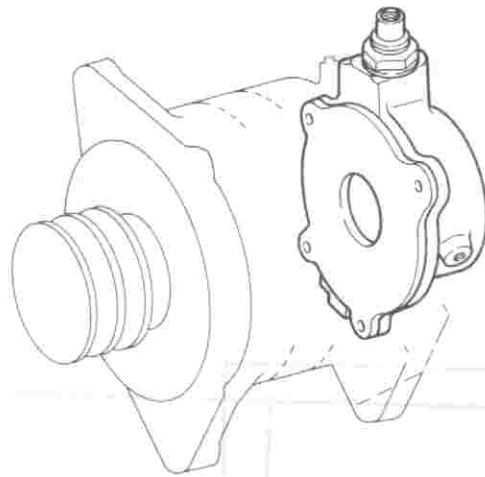

★ Non-reusable parts

- ① Vacuum pump blade
- ② Packing
- ③ Pin

- ④ Gasket
- ⑤ Check valve

2. CHARGING SYSTEM CIRCUIT

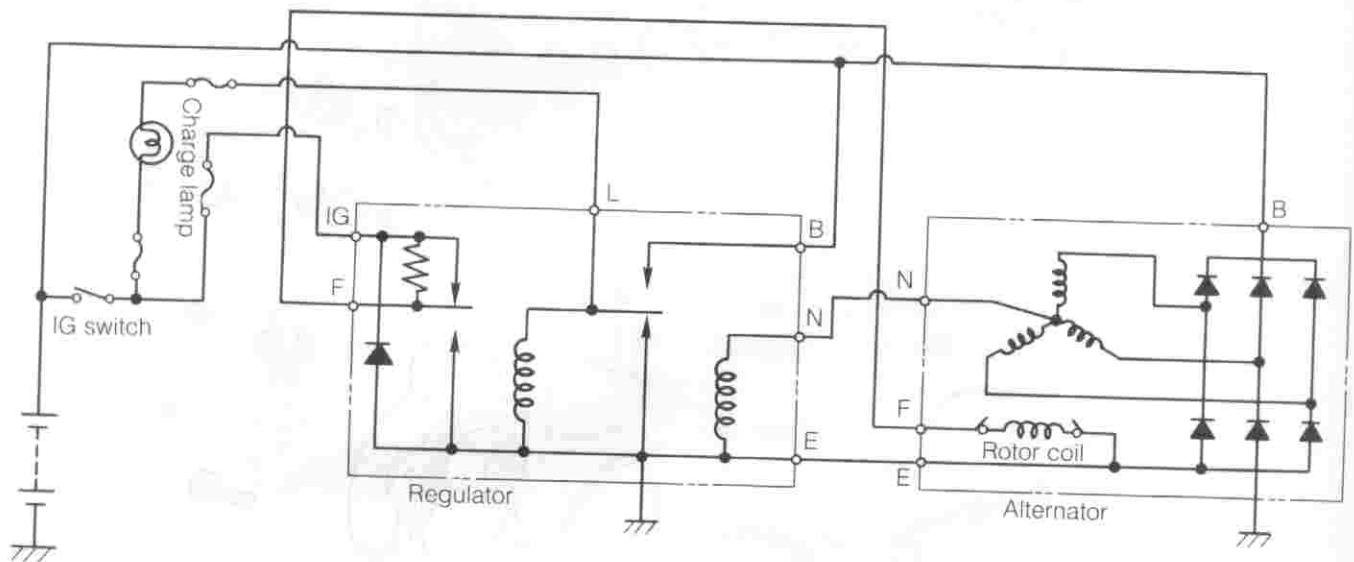

3. IN-VEHICLE INSPECTION

(1) Prior to the in-vehicle inspection, be sure to perform the following checks.

- ① Specific gravity of battery
- ② Installation of battery terminals
- ③ Tension of V-belt
- ④ Fuse
- ⑤ Wiring harness
- ⑥ Abnormal noise emitted from alternator while engine is rotating.

(2) Output test under unloaded state

- ① Ensure that all switches are turned OFF so that no unnecessary electric load may be applied.
 - Headlamps
 - Heater blower
 - Radio
 - Rear defogger
 - Room lamp, etc.

② Raise the engine revolution speed gradually. Measure the current and voltage.

Specifications: Not to exceed 10 A
13.8 - 14.8 V (20 °C)

If the measured voltage is not within the specifications, adjust the regulator or replace the regulator, as required.

(3) Output test under loaded state

- ① To apply electric load, perform the following operation.
 - a. Set the headlamps to the upper beam position.
 - b. Set the heater blower to the "High" position.
- ② Measure the output current at the engine speed of 1300 rpm.

Specified Value: 20 A

If the ammeter reading is less than the specified amperage, repair the alternator.

NOTE:

- When the battery is fully charged, the measured current may be below the specified value.
- This is not an abnormal phenomenon. At this time, increase the electric load, for example, by turning ON the rear defogger. Then, check to see if the output current rises or not.

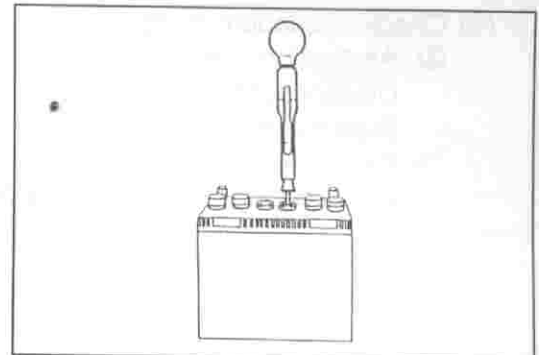

WRE91-CH005

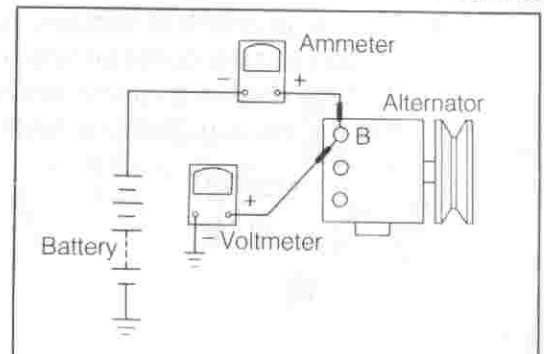

WRE91-CH006

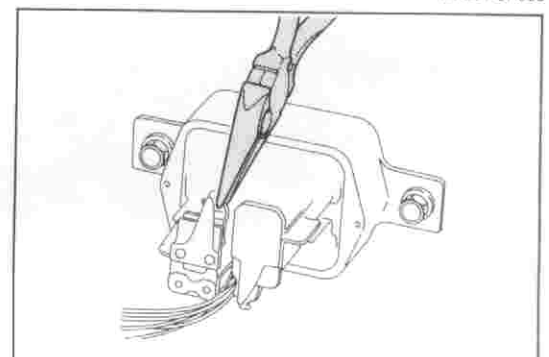

WRE91-CH007

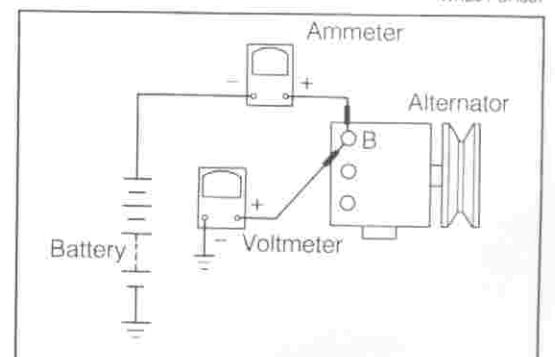

WRE91-CH008

CHARGING SYSTEM

(4) Check of vacuum pump

① Air suction check of vacuum pump

Disconnect the air inlet hose of the vacuum pump. Start the engine. Hold your finger at the end of the inlet hose. If you can feel suction, it indicates that vacuum pump is functioning properly.

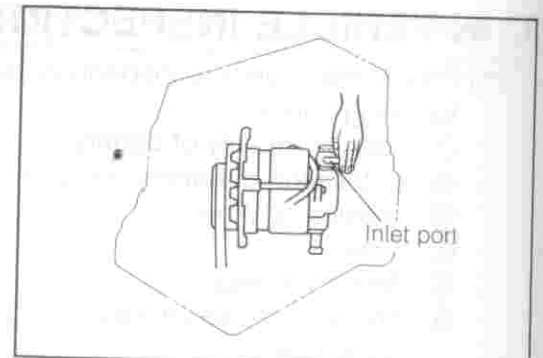

WRE91-CH009

② Discharge check of vacuum pump

Disconnect the outlet oil hose of the vacuum pump. Start the engine. If oil and air are discharge, it shows that the vacuum pump is functioning properly.

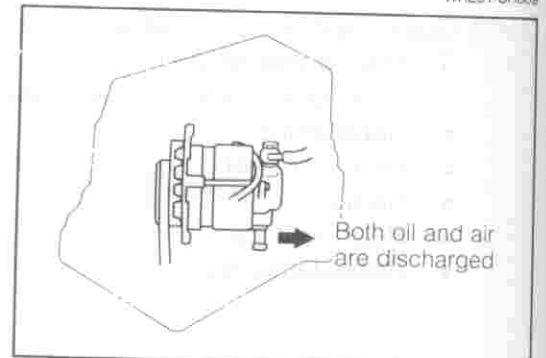

WRE91-CH010

4. REMOVAL OF ALTERNATOR

- (1) Disconnect the ground cable terminal from the negative (-) terminal of the battery.
- (2) Remove the air cleaner and oil filter.
- (3) Disconnect the (+) B wire and connector from the alternator.
- (4) Remove the vacuum hose from the vacuum pump.

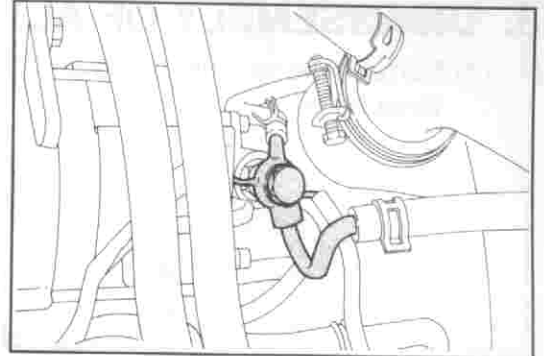

WRE91-CH011

- (5) Disconnect the oil hose.
- (6) Remove the alternator by removing the lock bolts.

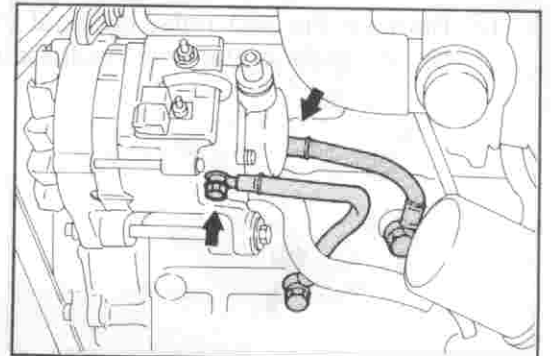

WRE91-CH012

CHARGING SYSTEM

5. DISASSEMBLY OF ALTERNATOR

(1) Remove the vacuum pump and O-ring by removing the three bolts.

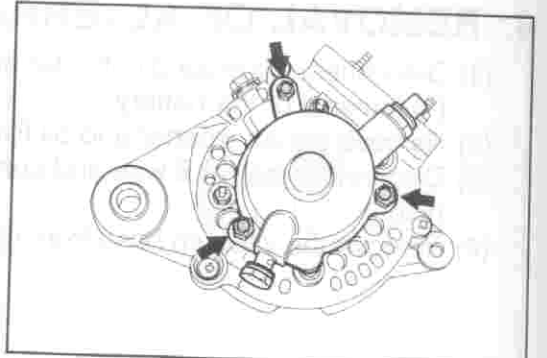

WRE91-CH013

(2) Remove the two nuts, terminal insulator, wire clamp, brush holder cover and insulator washer.

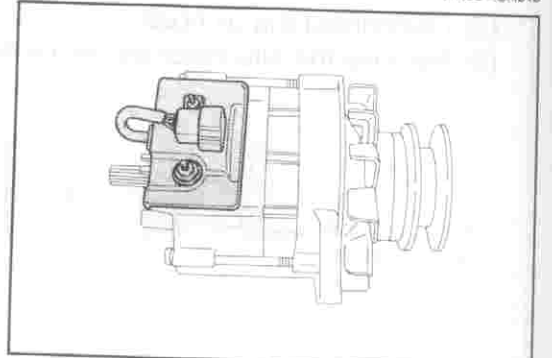

WRE91-CH014

(3) ① Disconnect the lead wire from the terminal B.
② Remove the brush holder by removing the nuts.

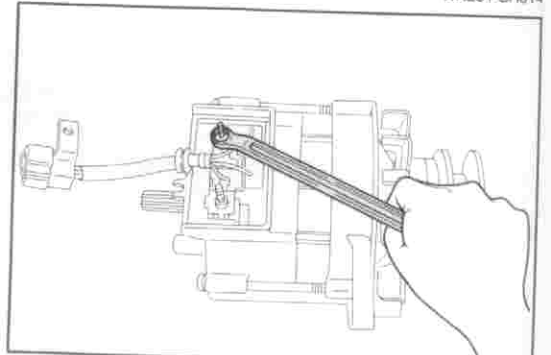

WRE91-CH015

(4) Remove the three through-bolts.

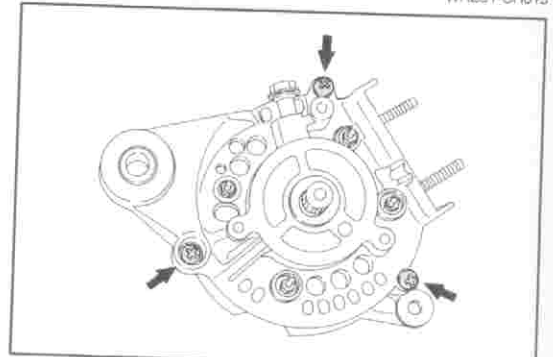

WRE91-CH016

(5) Clamp the rotor in a vise. Remove the lock nut, pulley, fan and collar.

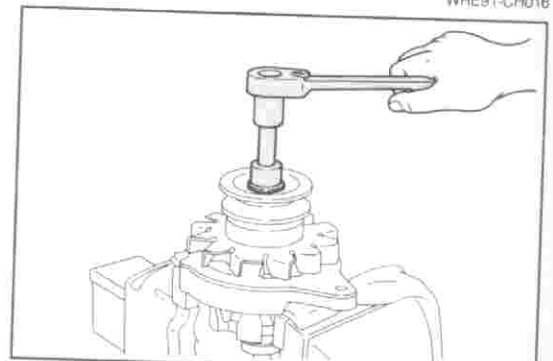

WRE91-CH017

- (6) Press off the rotor by means of a press in conjunction with a suitable steel pipe.

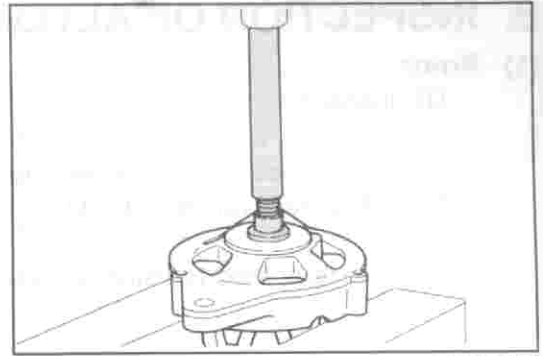

WRE91-CH018

- (7) Remove the rear end frame by removing the four nuts and two terminal insulators.

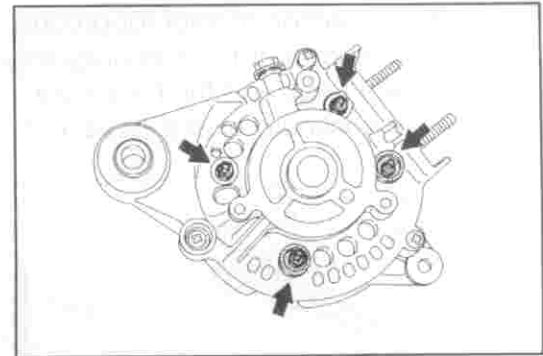

WRE91-CH019

- (8) Using a soldering iron, melt the solder while clamping the stator coil by means of needle-nose pliers.

NOTE:

- Protect the rectifiers from heat during the solder melting operation.

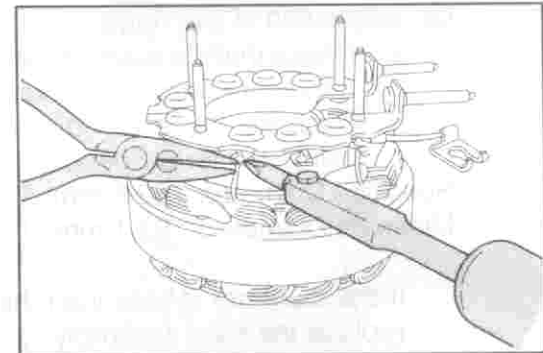

WRE91-CH020

6. INSPECTION OF ALTERNATOR

(1) Rotor

- ① Inspection of rotor for open circuit
Using an ohmmeter, check to see if the specified resistance exists between the rotor slip rings.

Specified Resistance: 4.0 Ω

If no specified resistance exists, replace the rotor.

- ② Inspection of rotor for ground
Ensure that no continuity exists between the rotor slip rings and the rotor core.
If continuity exists, replace the rotor.

- ③ Inspection of slip rings
a. Check that the slip rings are not rough or scored.
If they are rough or scored, replace the rotor.
b. Measure the outer diameter of the slip ring, using vernier calipers.

Specified Diameter: 32.5 mm

Minimum Diameter: 32.1 mm

If the diameter is less than the minimum diameter, replace the rotor assembly.

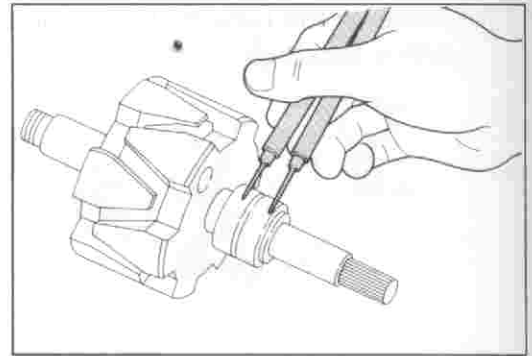

WRE91-CH021

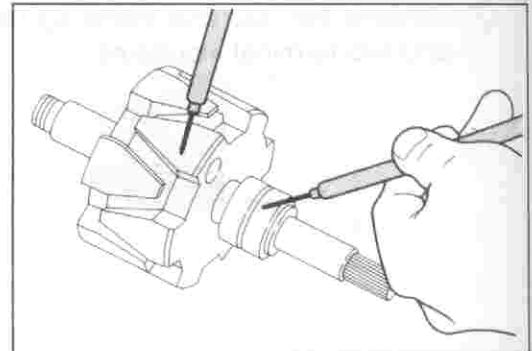

WRE91-CH022

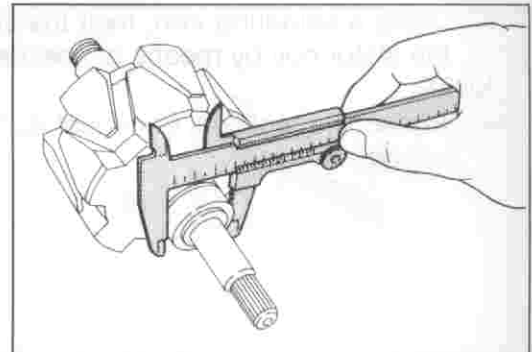

WRE91-CH023

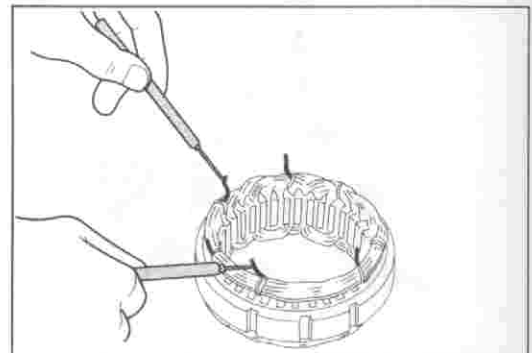

WRE91-CH024

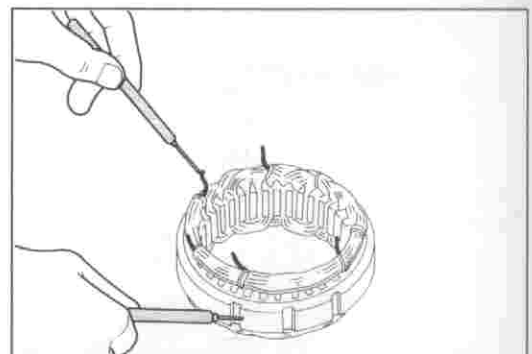

WRE91-CH025

(2) Stator

- ① Inspection of stator for open circuit
Using an ohmmeter, check that there is continuity between the coil leads.
If there is no continuity, replace the stator.

- ② Inspection of stator for ground
Using an ohmmeter, check that there is no continuity between the coil leads and the stator core.
If there is continuity, replace the stator.

(3) Brushes

- ① Measurement of exposed brush length
 Using a scale, measure the exposed brush length.
Specified Exposed Length: 20.0 mm
Minimum Exposed Length: 14.9 mm

If the exposed length is less than the minimum length, replace the brushes.

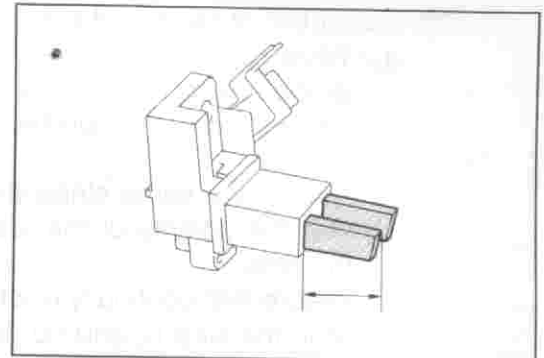

WRE91-CH026

- ② Replacement of brushes (If necessary)
- a. Remove the brush and spring from the brush holder by melting the solder by means of a soldering iron.

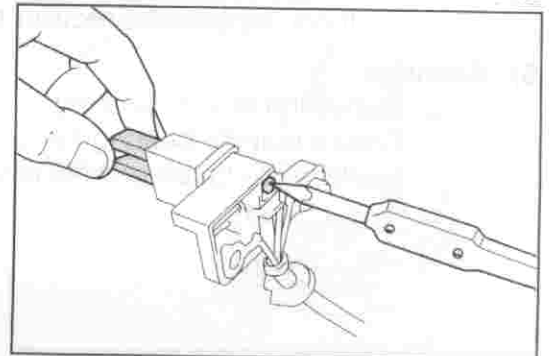

WRE91-CH027

- b. Insert the brush wire through the spring.
- c. Install the brush in the brush holder.
- d. Solder the brush wire to the brush holder at the specified exposed length.
Specified Exposed Length: 20.0 mm
- e. Check that the brush moves smoothly in the brush holder.
- f. Cut off any excess wire.

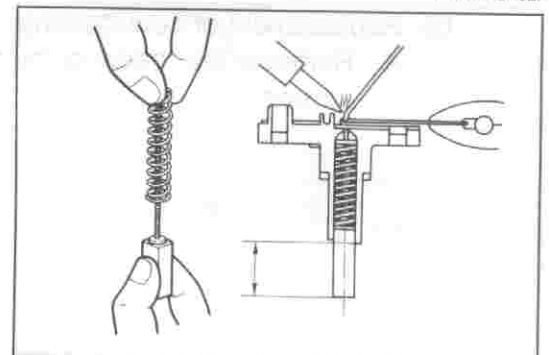

WRE91-CH028

(4) Rectifier

- ① Inspection of rectifier at positive ⊕ side
- a. While using an ohmmeter, connect one tester probe to the positive stud. Also, connect the other probe to each of the rectifier terminals.
 - b. Repeat the same steps described in a, above with the polarity of the tester probes reversed this time.
 - c. Ensure that continuity exists either in the step a, or in the step b, and no continuity exists at the other test.

If not, replace the rectifier holder.

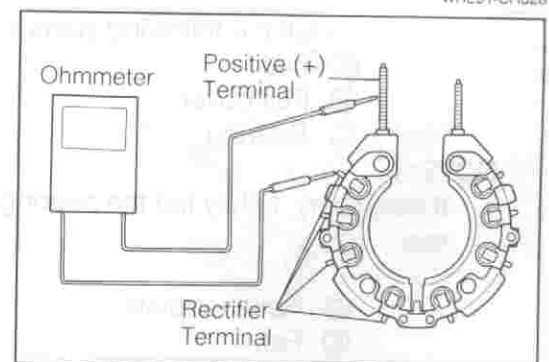

WRE91-CH029

CHARGING SYSTEM

- ② Inspection of rectifier at positive \ominus side
 - a. While using an ohmmeter, connect one tester probe to each rectifier negative terminal. Also, connect the other probe to each rectifier terminals.
 - b. Repeat the same steps described in a, above with the polarity of the tester probes reversed this time.
 - c. Ensure that continuity exists either in the step a, or in the step b, and no continuity exists at the other test.

If not, replace the rectifier holder.

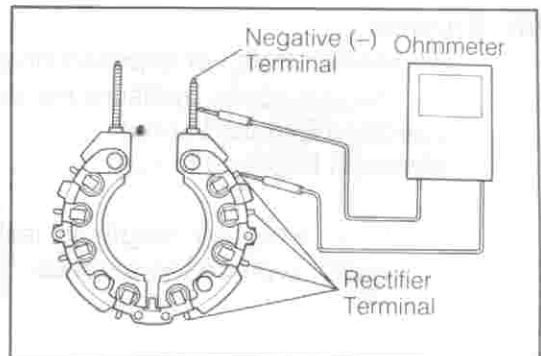

WRE91-CH030

(5) Bearings

- ① Inspection of front bearing
Ensure that the bearing turns smoothly.
Replace the bearing, if necessary.

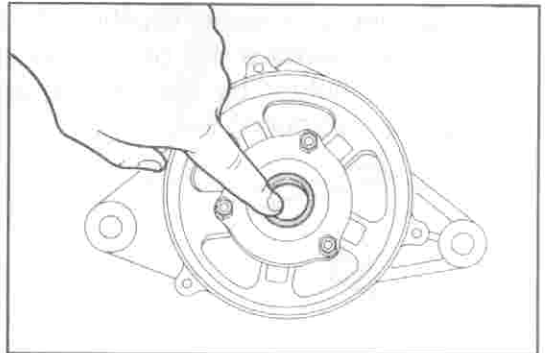

WRE91-CH031

- ② Replacement of front bearing
 - a. Remove the bearing by removing the three screws.

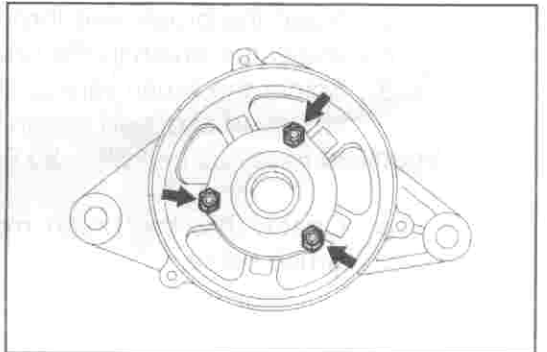

WRE91-CH032

- b. Install the following parts with the three bolts.
 - (A) Felt
 - (B) Felt cover
 - (C) Bearing

NOTE:

- If necessary, lightly tap the bearing with a plastic hammer.

- (D) Retainer plate
- (E) Felt
- (F) Felt cover

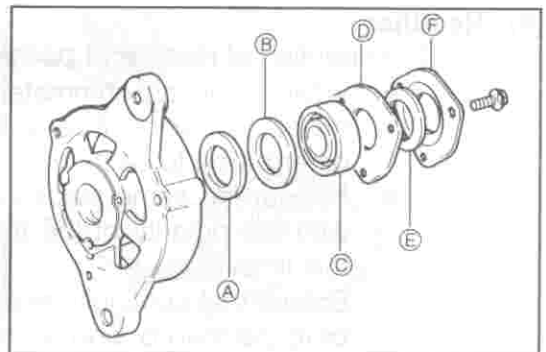

WRE91-CH033

7. ASSEMBLY OF ALTERNATOR

- (1) Install the stator coil by melting the solder while clamping the stator coil by means of needle-nose pliers.

NOTE:

- Protect the rectifiers from heat during the solder melting operation.

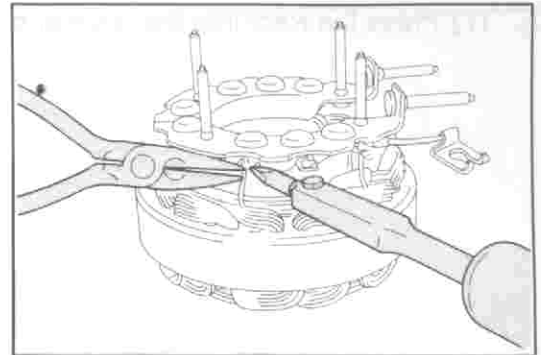

WRE91-CH034

- (2) ① Place the two insulators on the positive (+) studs of the rectifier holder.
 ② Place the two collars on the negative (-) studs of the rectifier holder.

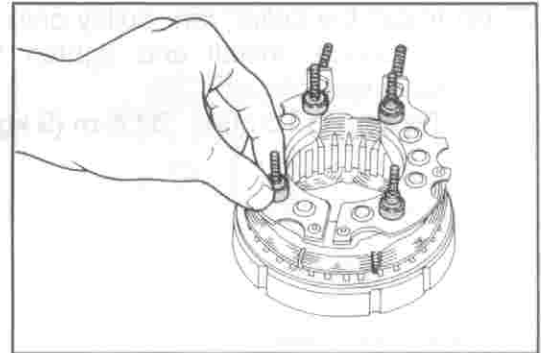

WRE91-CH035

- (3) Place the rear end frame on the rectifier holder.
 (4) Place the two insulators on the positive (+) studs of the rectifier holder.

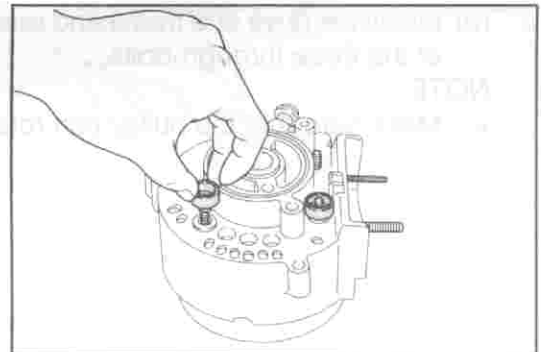

WRE91-CH036

- (5) Install the four nuts.

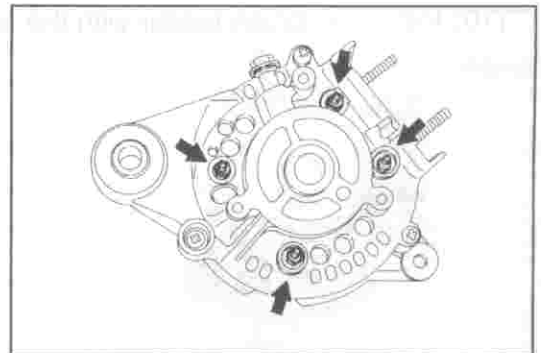

WRE91-CH037

- (6) ① Install the snap ring.
 ② Install the spacer ring.

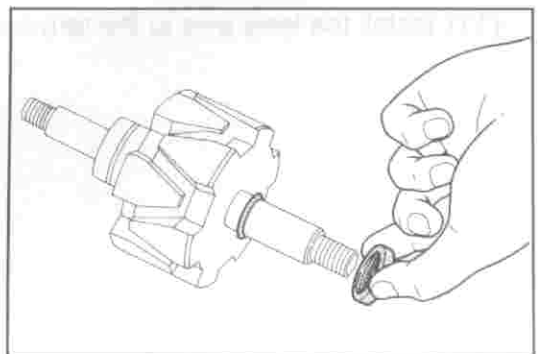

WRE91-CH038

CHARGING SYSTEM

(7) Press the rotor into the drive end frame, using a press.

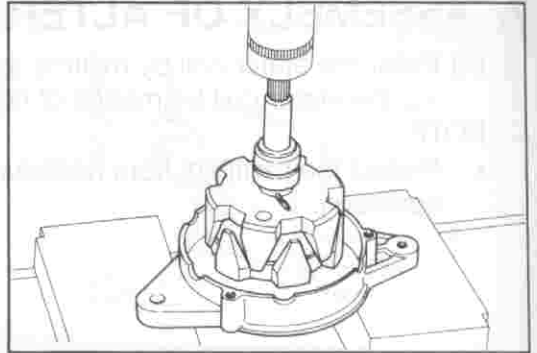

(8) Install the collar, fan, pulley onto the rotor shaft in this sequence. Install and tighten the lock nut to the specified torque.

Tightening Torque: 88 N·m (9 kgf·m, 65 ft·lb)

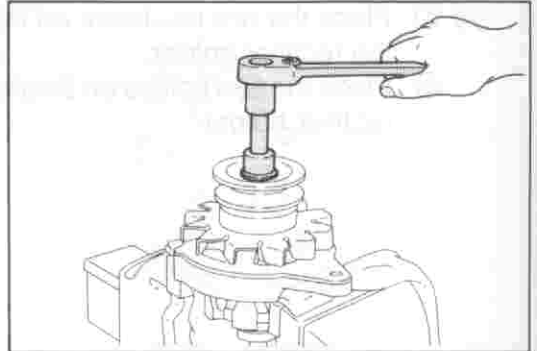

(9) Install the drive end frame and rear end frame by means of the three through-bolts.

NOTE:

- Make sure that the pulley can rotate smoothly.

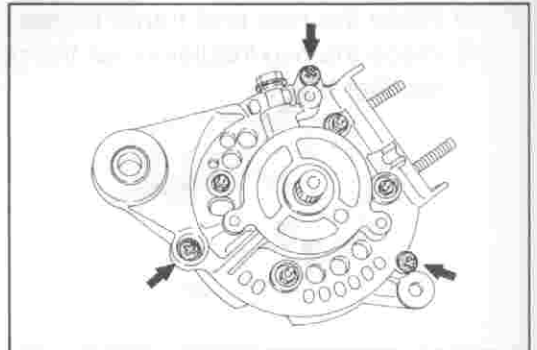

(10) Install the brush holder with the nuts.

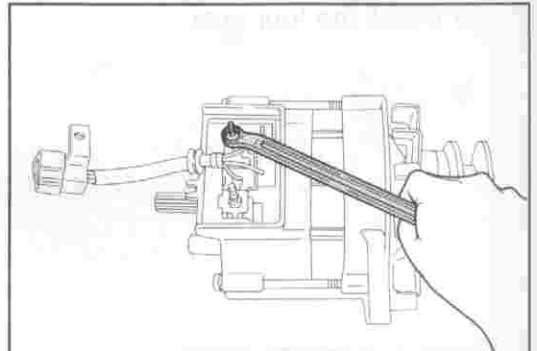

(11) Install the lead wire to the terminal B.

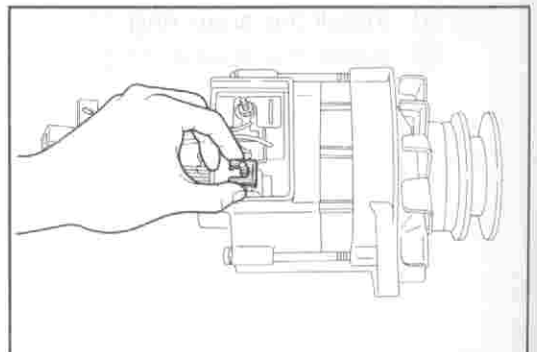

(12) Place the insulator washer to the terminal B.

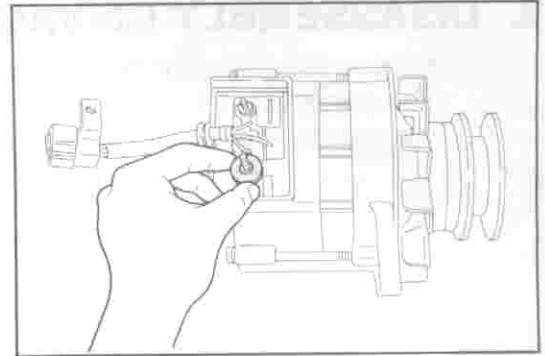

WRE91-CH044

- (13) ① Place the brush holder on the end frame.
② Place the terminal insulator on the terminal B.
③ Place the connector clamp on the other terminal.
Install the nut.

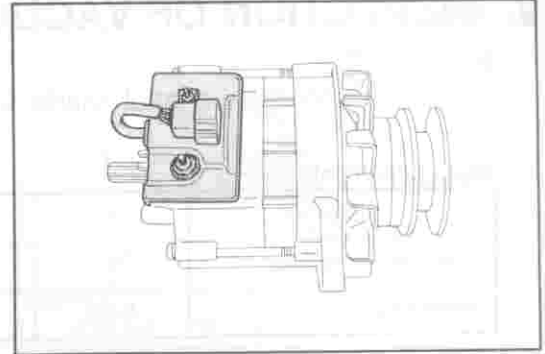

WRE91-CH045

(14) Place a new O-ring on the rear end frame.

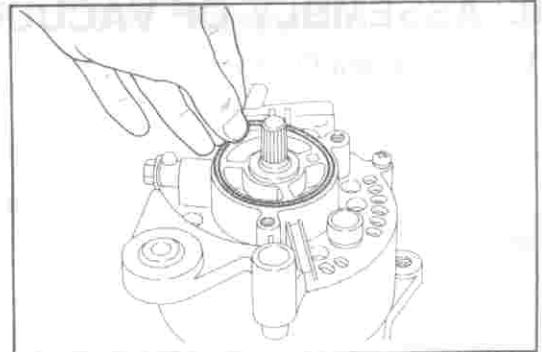

WRE91-CH046

(15) Install the vacuum pump with the three bolts.
Tightening Torque: 7.8 N-m (0.8 kgf-m, 5.8 ft-lb)

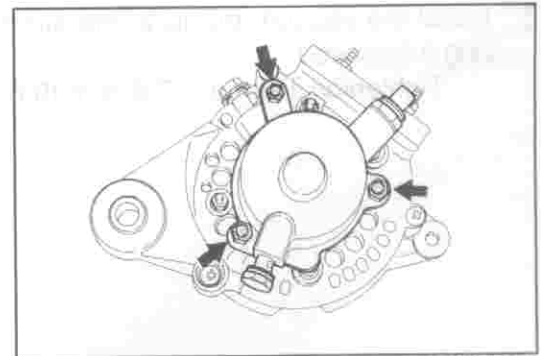

WRE91-CH047

CHARGING SYSTEM

8. DISASSEMBLY OF VACUUM PUMP

- (1) Remove the alternator from the vehicle.
(See page, CH-7.)
- (2) Remove the vacuum pump by removing the three bolts.

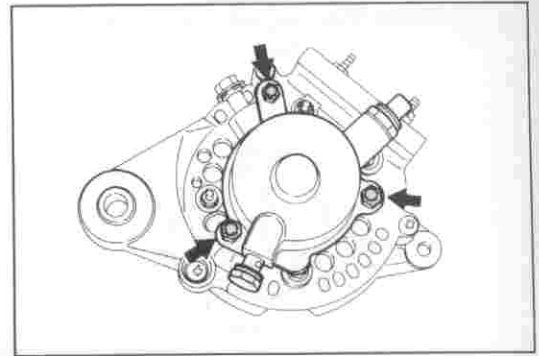

WRE91-CH048

9. INSPECTION OF VACUUM PUMP

Blade

Check the worn state of each blade, using vernier calipers.

Blade Specifications

| Item | A | B | C |
|---------------------|------|-------|------|
| Specified dimension | 6 | 23 | 14.7 |
| Wear limit | 5.95 | 22.98 | 13.3 |

mm

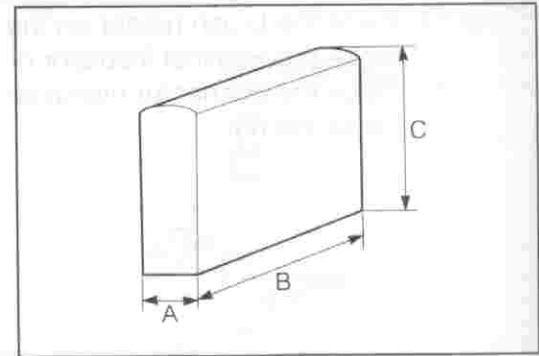

WRE91-CH049

10. ASSEMBLY OF VACUUM PUMP

1. Install a new O-ring.

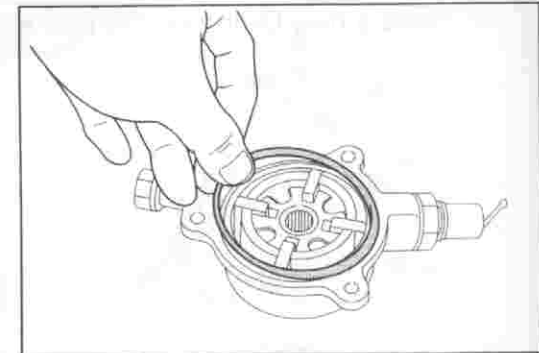

WRE91-CH050

2. Install the vacuum pump to the alternator with a new "O"-ring interposed.

Tightening Torque: 7.8 N-m (0.8 kgf-m, 5.8 ft-lb)

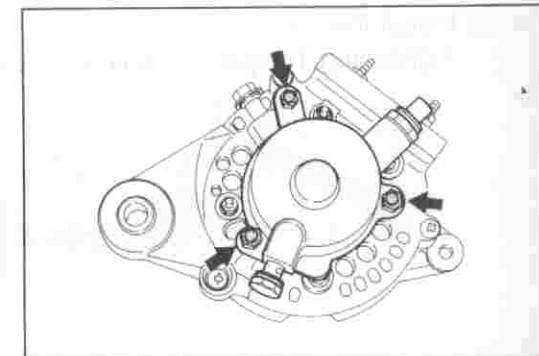

WRE91-CH051

11. INSTALLATION OF ALTERNATOR

- (1) Temporarily install the alternator on the engine with the two attaching bolts.
- (2) Install the oil hose with a new gasket interposed.

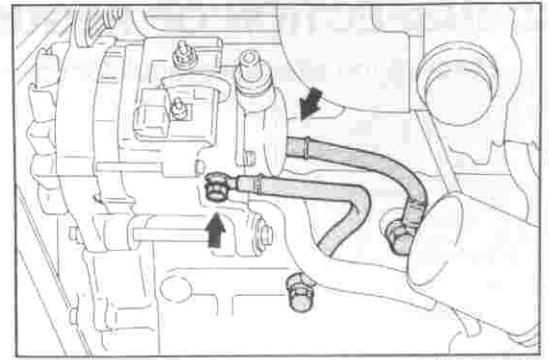

WRE91-CH052

- (3) Install the vacuum hose, using new clips.

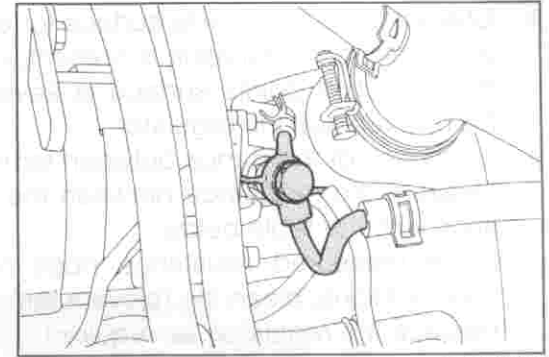

WRE91-CH053

- (4) Adjust the V-belt properly and secure the alternator.
Specified Belt Deflection: 10 - 13 mm/10 kgf (98 N)
- (5) Install the (+) B wire and connector to the alternator.
- (6) Install the air cleaner and oil filter.
- (7) Connect the ground cable terminal to the negative (-) terminal of the battery.

WRE91-CH054