

DAIHATSU

F300

[HD-ENGINE]

MA

MAINTENANCE

MAINTENANCE SCHEDULE	MA-2
MAINTENANCE OPERATIONS	MA-3
COLD ENGINE OPERATIONS	MA-3
HOT ENGINE OPERATIONS	MA-8

WN88E-MA001

MAINTENANCE

MAINTENANCE SCHEDULE

O ... Check ● ... Change or replacement

Section	Inspection	× 1,000 km	1	5	10	15	20	25	30	35	40	45	50	55	60	65	70	75	80	85	90	95	100	
		× 1,000 miles	0.6	3	6	9	12	15	18	21	24	27	30	33	36	39	42	45	48	51	54	57	60	
		(Months) Years	—	(3)	(6)	(9)	1	(3)	(6)	(9)	2	(3)	(6)	(9)	3	(3)	(6)	(9)	4	(3)	(6)	(9)	5	
Engine electrical system	• Distributor cap, rotor	• Damage					○				○				○				○				○	
	• Spark plug	• Cleaning					○				○				○				○				○	
	• Ignition timing	• Timing					○				○				○				○				○	
	• Battery	• Electrolyte level		○	○	○	○	○	○	○	○	○	○	○	○	○	○	○	○	○	○	○	○	○
	• Wire harness	• Tightness clamps • Damage		○	○	○	○	○	○	○	○	○	○	○	○	○	○	○	○	○	○	○	○	○
Engine	• Air cleaner element* ¹	• Cleaning			○	○	○	○	○	●	○	○	○	○	○	○	○	○	○	○	○	○	○	
	• Valve clearance	• Clearance									○								○					
	• Engine oil* ² (API SE or SF)	• Leakage • Level • Change (Every 10,000 km or 0.5 year)	●	○	●	○	●	○	●	○	●	○	●	○	●	○	●	○	●	○	●	○	●	
	• Oil filter* ²	• Change			●	●	●	●	●	●	●	●	●	●	●	●	●	●	●	●	●	●	●	
	• Fuel filter	• Change	• HD-C engine								●								●					
			• HD-E engine																					●
	• Fuel lines & Connections	• Damage • Crack • Tightness • Leakage		○			○				○				○				○					○
	• Carburetor (HD-C engine)	• Idle speed • Acceleration					○				○				○				○					○
	• Choke system (HD-C engine)	• Operation					○				○				○				○					○
	• Coolant	• Quantity • Leakage • Change (Long life coolant)		○	○	○	○	○	○	○	●	○	○	○	○	○	○	○	○	○	○	○	○	○
	• V-belt	• Tension • Crack • Damage		○	○	○	○	○	○	○	○	○	○	○	○	○	○	○	○	○	○	○	○	○
	• Blow-by gas ventilation hose	• Connection • Damage										○							○					
	• Throttle positioner	• Operation					○				○				○				○					
• Spark control system	• Operation					○				○				○				○						
• Charcoal canister	• Operation					○				○				○				○					○	

*¹ In case of driving on dusty roads, clean every 2,500 km (1,500 miles) and replace every 20,000 km (12,000 miles).
 *² In case of severe driving condition, replace every 5,000 km (3,000 miles).

MAINTENANCE OPERATIONS

COLD ENGINE OPERATIONS

1. Inspection of distributor cap and rotor.
Visually inspect the distributor for cracks, wear or damage.

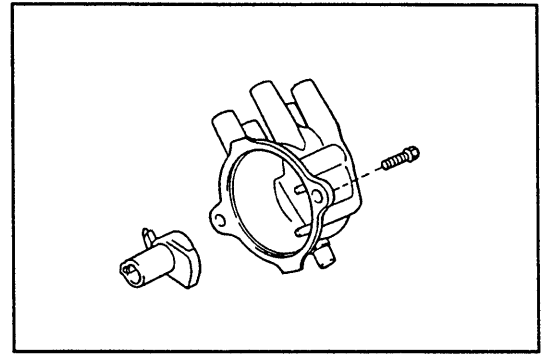

WN88E-MA003

2. Inspection and cleaning of spark plugs
 - (1) If there are traces of oil, remove it with gasoline before the spark plug is cleaned by the spark plug cleaner.

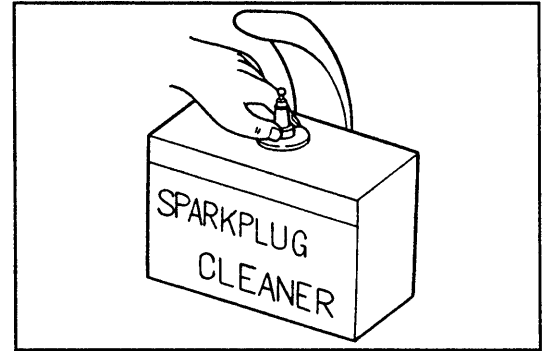

WN88E-MA004

- (2) Measure the electrode gap, using a plug gap gauge.

Recommended a plug gap.

Spark plug	Air gap mm (inch)
Champion: RC9YC4	1.0 - 1.1 (0.039 - 0.043)
ND: K20PR-U11	
NGK: BKR 6E-11	

**Tightening Torque of Spark Plug: 1.5 - 2.2 kg-m
(10.8 - 15.9 ft-lb)**

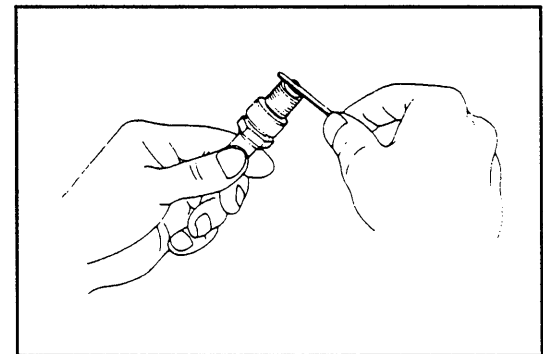

WN88E-MA005

3. Check of battery electrolyte level
 - (1) Visually check the electrolyte level between the upper line and the lower line.
 - (2) If the electrolyte level is below the lower level, replenish distilled water up to the upper level.

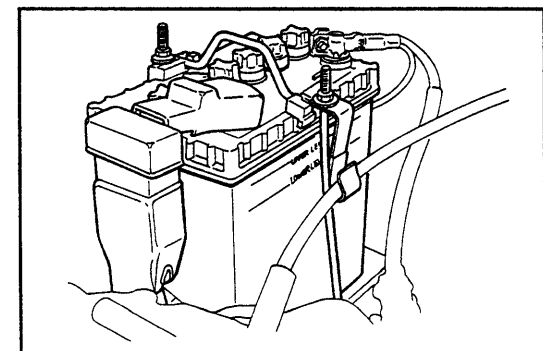

WN88E-MA006

MAINTENANCE

4. Check of wiring harness clamp
Visually check that the wiring harness is suitable clamp, damaged.

WN88E-MA007

5. Cleaning of air cleaner filter element
 - (1) Remove the air cleaner filter element from the air cleaner case.
 - (2) Clean the element with compressed air. First blow from the back side thoroughly. Then, blow off the front side of the element.

CAUTION:

The air pressure to be used for this cleaning operation should not exceed 4.0 kg/cm² (56.9 psi)

- (3) Install the air cleaner filter element in the air cleaner.

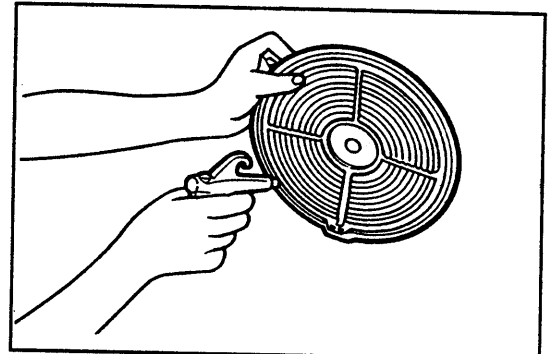

WN88E-MA008

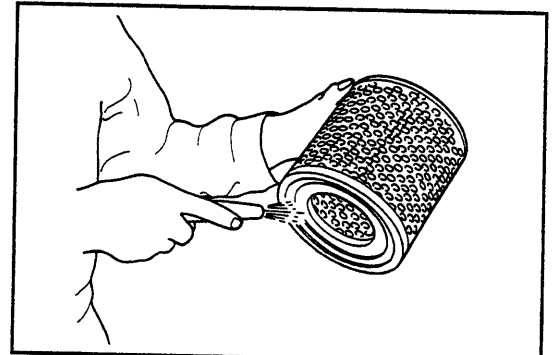

WN88E-MA009

6. Engine oil change
(See page LU-4)
Recommended oil grade: API grade SE, SF
Oil capacity
When only engine oil is changed: 3.3 liter
When engine oil is changed and oil filter is replaced: 3.5 liter

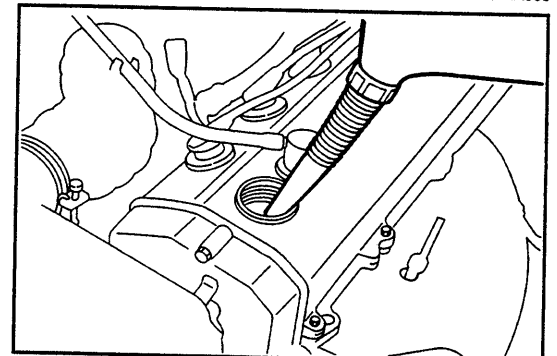

WN88E-MA010

7. Engine oil filter replacement
 - (1) Remove the oil filter, using the following SST.
SST: 09228-87201-000

NOTE:
Since the oil flows out during the replacement, receive the oil with an adequate container.

 - (2) Inspect and clean the oil filter installation surface.

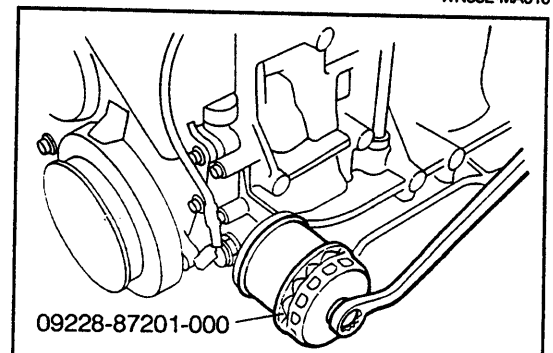

WN88E-MA011

- (3) Apply clean engine oil to the gasket of a new oil filter.
- (4) Installation of oil filter
Screw in the oil filter lightly by hand until the oil seal surface contacts the oil cooler.
Then, tighten the oil filter one more turn, using the SST.
SST: 09228-87201-000

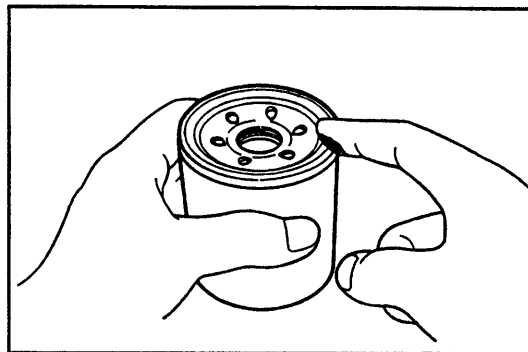

WN88E-MA012

- 8. Fuel filter replacement
Carburetor installed engine:
Disconnect the hose clamp. Then, replace the fuel filter.

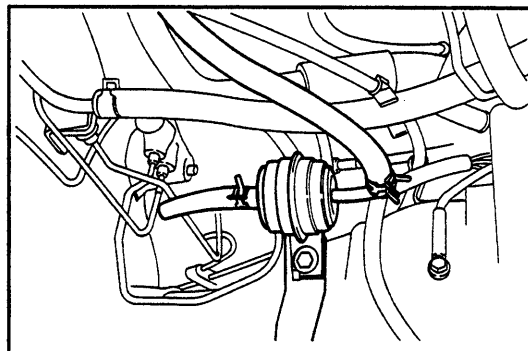

WN88E-MA013

- EFI installed engine:
Loosen the union bolt slowly and pull it out.
- WARNING:**
The fuel in the fuel pipe is pressurized to a pressure of 2.55 kg/cm^2 (36.27 psi).
Therefore, the union bolt should be removed slowly. Otherwise, the fuel may be splashed.

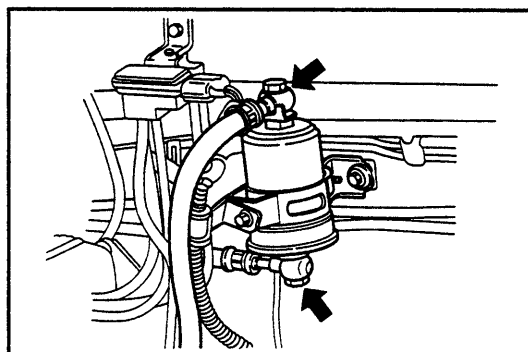

WN88E-MA014

- 9. Inspection of fuel lines and connections
Visually inspect the fuel lines for cracks, leakage, loose connections, or deformation.

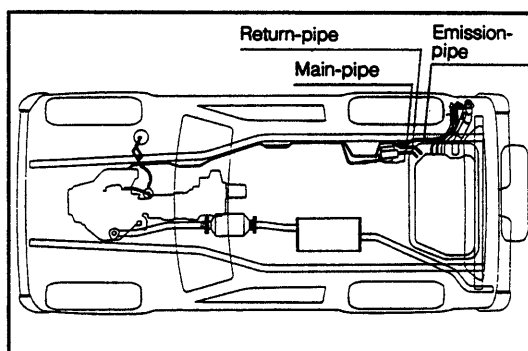

WN88E-MA015

- 10. Inspection of auto choke system (Only for HD-C)
Check that choke valve is completely closed when cold engine.
Then, start the engine, check that choke valve is gradually opened in accordance with the warning-up condition of the engine.

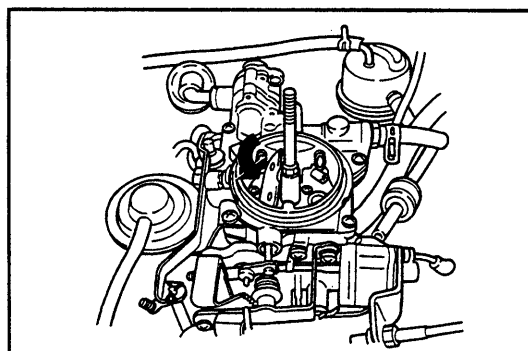

WN88E-MA016

MAINTENANCE

11. Check of engine coolant

(1) Check of cooling system for leakage

Apply a pressure of 1.2 kg/cm² (17 psi) to the cooling system by means of a radiator tester.

Ensure that the pressure does not drop.

WARNING:

Never remove the radiator tester when the coolant temperature is still high.

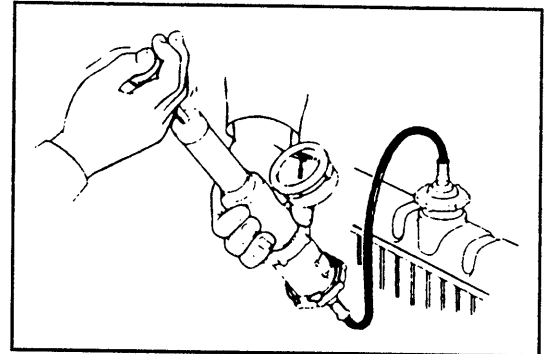

WN88E-MA017

(2) Check of coolant level

Check to see if the coolant level is between the LOW and FULL lines of the reserve tank.

If the coolant level is near the low level or below the low level, add the coolant up to the full level.

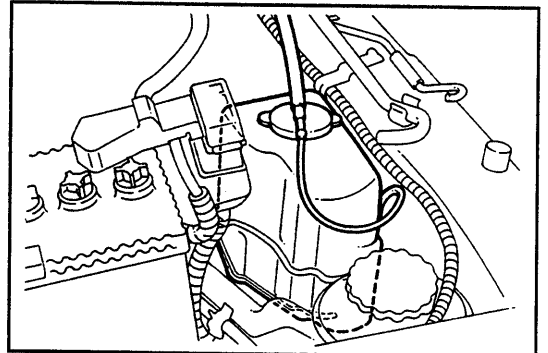

WN88E-MA018

12. Inspection of drive belt

(1) Visually check the V belt for separation of the adhesive rubber above and below the core, core separation from the belt side, severed core, separation of the rib from the adhesive rubber, cracks or separation of the ribs, torn or worn ribs or cracks in the inner ridges of the ribs.

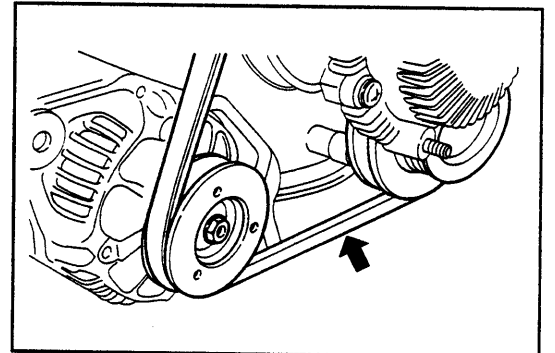

WN88E-MA019

(2) Measure the amount of the drive belt deflection when the midpoint of the drive belt between the alternator and the water pump pulley is pushed with a force of 10 kg (2.20 lb)

Specified Belt Deflection

New belt: 5.0 - 7.0 mm (0.20 - 0.28 inch)

Used belt: 6.0 - 8.0 mm (0.24 - 0.31 inch)

NOTE:

- "New belt" refers to a belt which has been used on a running engine for less than five minutes.
- After installing a new belt, run the engine for about five minutes and then recheck the tension.

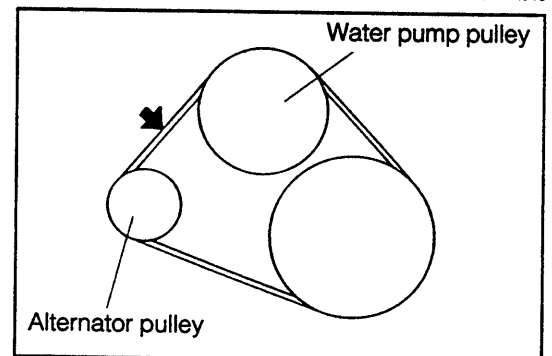

WN88E-MA020

13. Inspection of blow-by gas recirculating system
 Check the hose, connections for cracks, leak or damage.

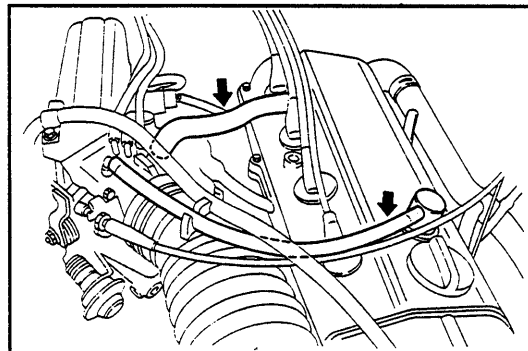
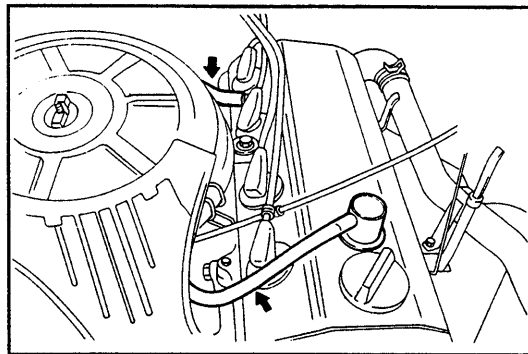

WN88E-MA021

14. Inspection of charcoal canister
 (1) Disconnect the rubber hoses and remove the charcoal canister.

HD-E:

- (2) Blow air of 3 kg/cm^2 (43 psi) into the pipe (B) while holding the pipe (A) closed.
 Ensure that air flows smooth from the pipe (C).

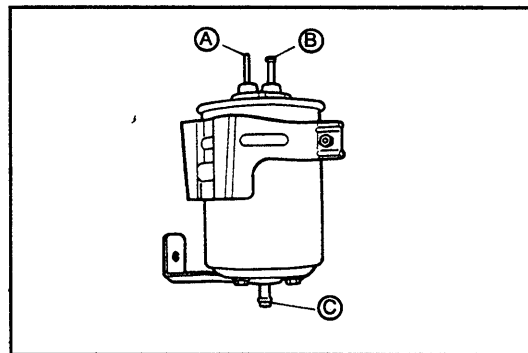

WN88E-MA022

HD-C (Only for GCC Specifications)

Plug the pipe (A) and (B) with your fingers and blow compressed air of 3 kg/cm^2 (43 psi) through the pipe (C) (fuel tank side).

- Check that the air comes out of the bottom pipe (D).
- Check that no activated charcoal comes out.

NOTE:

Do not attempt to wash the charcoal canister.

- (3) Install the charcoal canister and reconnect the rubber hose.

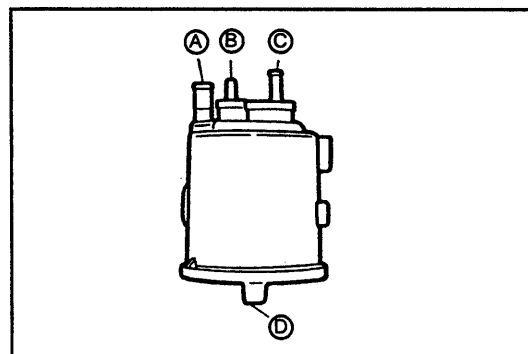

WN88E-MA023

15. Removal of timing belt (See page EM-21.)

WN88E-MA024

HOT ENGINE OPERATIONS

- Adjustment of ignition timing
 - Connect the tachometer to the ignition coil.
 - With the engine idling as specified, use a timing light to check the timing.
Ignition timing: $3^{\circ} \pm 2^{\circ}$ BTDC/850 rpm
 - If necessary, loosen the distributor bolts and turn the distributor to align the marks. Re-check the timing after tightening the distributor.

NOTE:

- Disconnect the vacuum hose of sub-diagram from the vacuum advancer of distributor and close the vacuum hose during test.
- The ignition coil has no terminal for external connection. Hence, insert an adequate jumper cord from the backside of the connector attached to the ignition coil. Then, connect the other end of the jumper cord to the measuring terminal of the tachometer.
- For the purpose of connecting tachometer, the SST for connecting to the distributor wire is available.
SST: 09991-87703-000

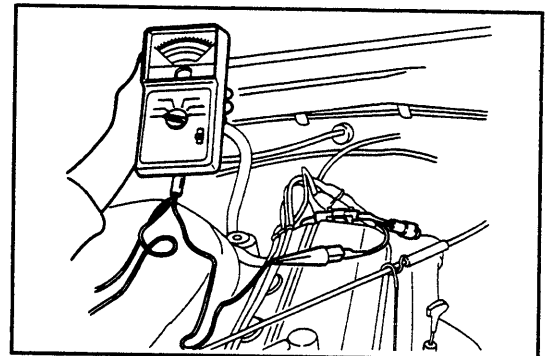

WN88E-MA025

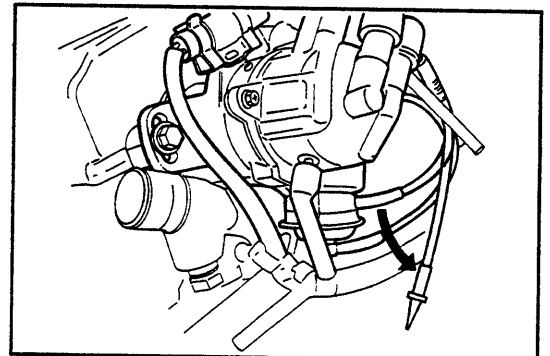

WN88E-MA026

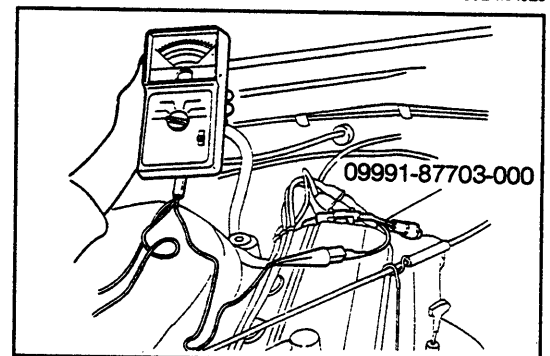

WN88E-MA027

CAUTION:

- Never allow the tachometer terminal to touch ground as it could result in damage to the ignitor and/or ignition coil.
- As some tachometers are not compatible with this ignition system, it is imperative to confirm the compatibility of your meter before it is used.

2. Adjustment of valve clearances (See page EM-9)

NOTE:

The valve clearance adjustment is performed normally when the engine is in a hot condition.

“Hot engine condition” denotes a condition in which the cooling water temperature is 75 - 85 °C (167 - 185°F) and the engine oil temperature is above 65°C (149°F).

Valve clearances (Hot condition)

Intake: 0.20 - 0.30 mm (0.0078 - 0.0118 inch)

Exhaust: 0.28 - 0.38 mm (0.0110 - 0.0150 inch)

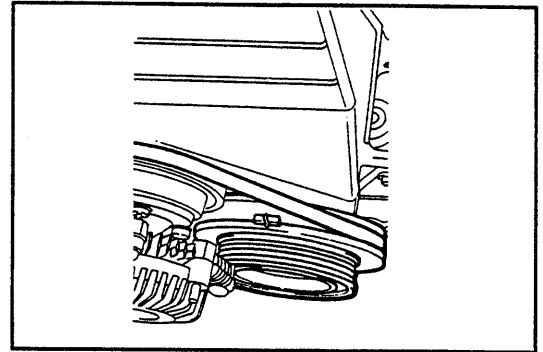

WN88E-MA029

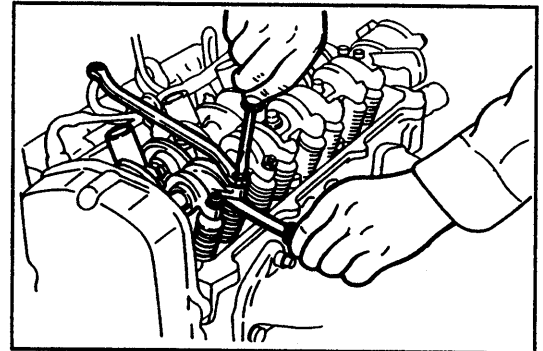

WN88E-MA030

3. Idle speed adjustment

(1) Preparation to be made prior to idle adjustment

- Warm up the engine thoroughly.
- All accessory switches are turned OFF.
On those vehicle equipped with a day-lamp system, set the lamp control switch to the first stage with head lamps turned OFF.
- The air cleaner element is installed.
- All vacuum hoses are connected.

(2) Connect the tachometer to the distributor. (See page MA-8)

(3) Adjustment

- Carburetor equipped vehicle
Adjust the throttle adjusting screw so that the engine idle speed may become the specified value.
Engine Idle Speed: 850 ± 50 rpm

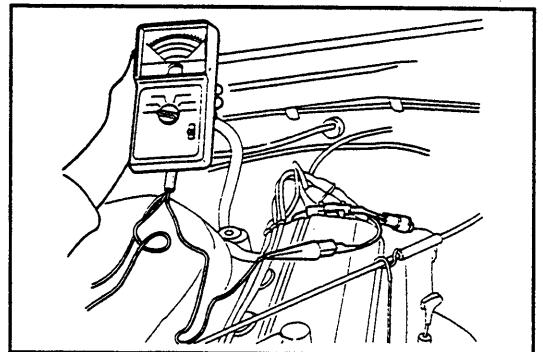

WN88E-MA031

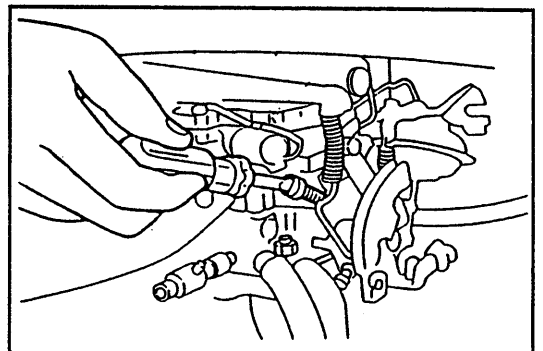

WN88E-MA032

- EFI equipped vehicle
Remove the idle adjusting screw cap from the throttle body. Then, set the idle speed by turning the idle speed adjusting screw.
Engine Idle Speed: 850 ± 50 rpm

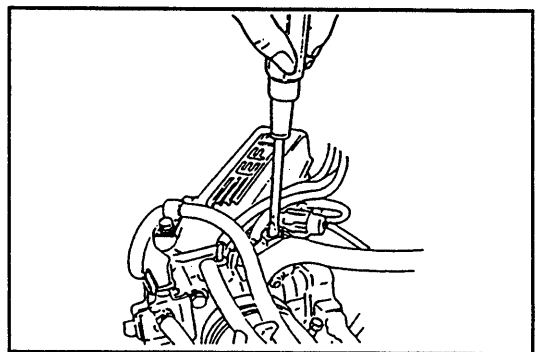

WN88E-MA033

MAINTENANCE

4. Inspection of throttle positioner system

- Carburetor equipped vehicle
 - (1) Warm up the engine.
 - (2) Raise the engine speed to approximately 2500 rpm and hold the engine speed at 2500 rpm for five seconds. Measure that the dashpot shaft is fully stretched.
 - (3) Close the throttle valve quickly.
 - (4) Make sure the time required for the engine speed to drop from 1500 rpm to 1200 rpm.
Specified Time: 0.5 - 5.0 second

NOTE:

Dashpot touch engine speed: 1500 ± 50 rpm

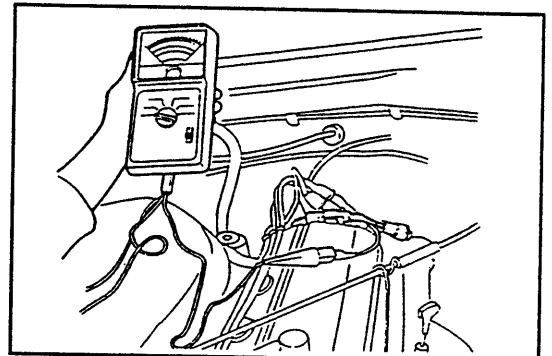

WN88E-MA034

- EFI equipped vehicle
 - (1) Warm up the engine.
 - (2) Raise the engine speed to approximately 3500 rpm and hold the engine speed at 3500 rpm for five seconds. Ensure that the dashpot lever should be fully extended.
 - (3) Close the throttle valve quickly.

WN88E-MA035

- (4) Measure the time required for the engine speed to drop from 1800 rpm to idle speed (850 ± 50 rpm).
Specified Time: 1.0 - 5.0 seconds

NOTE:

Dashpot touch engine speed: 1800 ± 100 rpm

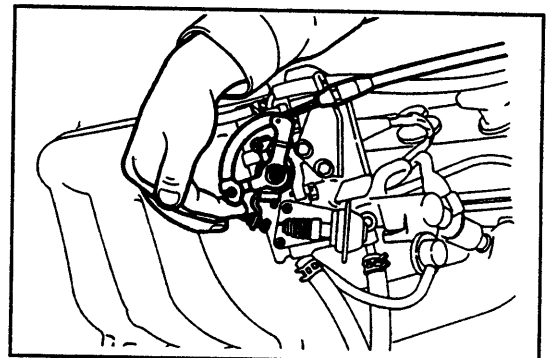

WN88E-MA036

5. Inspection of spark control system

- (1) Disconnect the vacuum hose of main and sub diagram from the vacuum advancer of distributor, and close the vacuum hose. Using a timing light, check the ignition advance timing, while engine speed is being raised.

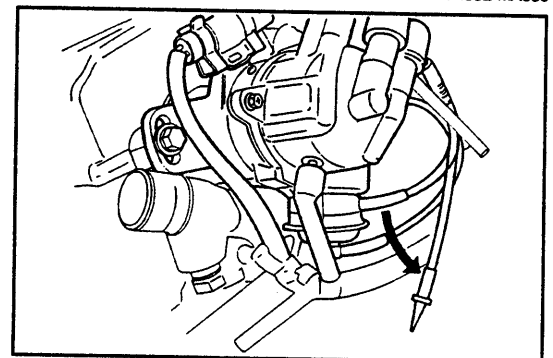

WN88E-MA037

- (2) Dis-connect the plug from vacuum hose. Connect the MitgVac to the vacuum advancer of distributor, check the ignition advance timing, while vacuum is applied.

WN88E-MA038